

**Central Coast Regional Water Quality Control Board**

**ORDER NO. R3-2017-0021  
NPDES NO. CA0048160**

**WASTE DISCHARGE REQUIREMENTS  
FOR THE GOLETA SANITARY DISTRICT WATER RESOURCE RECOVERY FACILITY  
DISCHARGE TO THE PACIFIC OCEAN**

The following Discharger is subject to waste discharge requirements as set forth in this Order:

**Table 1. Discharger Information**

<b>Discharger</b>	Goleta Sanitary District
<b>Name of Facility</b>	Goleta Sanitary District Water Resource Recovery Facility
<b>Facility Address</b>	One William Moffett Place
	Goleta, CA 93445-9735
	Santa Barbara County

**Table 2. Discharge Location**

Discharge Point	Effluent Description	Discharge Point Latitude	Discharge Point Longitude	Receiving Water
001	Secondary Treated Municipal Wastewater	34° 25' 19" N	119° 49' 56" W	Pacific Ocean
002	Disinfected Tertiary Recycled Domestic Wastewater	--	--	Reclamation Use

**Table 3. Administrative Information**

This Order was adopted by the Regional Water Quality Control Board on:	<b>September 21, 2017</b>
This Order shall become effective on:	<b>November 10, 2017</b>
This Order shall expire on:	<b>November 9, 2022</b>
The Discharger shall file a Report of Waste Discharge as an application for reissuance of waste discharge requirements in accordance with title 23, California Code of Regulations, and an application for reissuance of a National Pollutant Discharge Elimination System (NPDES) permit no later than:	<b>March 24, 2022</b>
The U.S. Environmental Protection Agency (USEPA) and the Central Coast Water Board have classified this discharge as follows:	<b>Major</b>

I, John M. Robertson, Executive Officer, do hereby certify that this order with all attachments is a full, true, and correct copy of an order adopted by the California Regional Water Quality Control Board, Central Coast Region on the date indicated above.

John M. Robertson, Executive Officer

**Contents**

I. Facility Information.....4

II. Findings .....4

III. Discharge Prohibitions.....5

IV. Effluent Limitations and Discharge Specifications.....5

    A. Final Effluent Limitations – Discharge Point No. 001 .....5

        1. Conventional and Non-Conventional Pollutants .....5

        2. Toxic Pollutants .....6

    B. Land Discharge Specifications – Not Applicable.....9

    C. Recycling Specifications – Discharge Point No. 002.....9

V. Receiving Water Limitations.....11

VI. Provisions.....13

    A. Standard Provisions.....13

    B. Monitoring and Reporting Program (MRP) Requirements.....13

    C. Special Provisions.....13

        1. Reopener Provisions.....13

        2. Special Studies, Technical Reports and Additional Monitoring Requirements.....14

        3. Best Management Practices and Pollution Prevention .....16

        4. Construction, Operation and Maintenance Specifications – Not Applicable.....17

        5. Special Provisions for Municipal Facilities (POTWs Only) .....17

        6. Other Special Provisions.....18

        7. Compliance Schedules – Not Applicable .....18

VII. Compliance Determination.....19

    A. General.....19

    B. Multiple Sample Data .....19

    C. Average Monthly Effluent Limitation (AMEL).....19

    D. Average Weekly Effluent Limitation (AWEL).....19

    E. Maximum Daily Effluent Limitation (MDEL) .....20

**Tables**

Table 1. Discharger Information .....1

Table 2. Discharge Location.....1

Table 3. Administrative Information.....1

Table 4. Effluent Limitations for Conventional and Non-Conventional Pollutants.....6

Table 5. Effluent Limitations – Protection of Marine Aquatic Life.....6

Table 6. Effluent Limitations – Protection of Human Health – Non-Carcinogens.....7

Table 7. Effluent Limitations – Protection of Human Health – Carcinogens.....7

Table 8. Toxicity Reduction Evaluation Schedule.....15

**Attachments**

Attachment A – Definitions..... A-1  
Attachment B – Map ..... B-1  
Attachment C – Flow Schematics..... C-1  
Attachment D – Standard Provisions..... D-1  
Attachment E – Monitoring and Reporting Program ..... E-1  
Attachment F – Fact Sheet..... E-1

## I. FACILITY INFORMATION

Information describing the Goleta Sanitary District Water Resource Recovery Facility (hereinafter the Facility) is summarized in Table 1 and in Fact Sheet (Attachment F) sections I and II. Section I of the Fact Sheet also includes information regarding the Facility's permit application.

## II. FINDINGS

The California Regional Water Quality Control Board, Central Coast Region (hereinafter Central Coast Water Board) finds:

- A. Legal Authorities.** This Order serves as waste discharge requirements (WDRs) pursuant to article 4, chapter 4, division 7 of the California Water Code (commencing with section 13260). This Order is also issued pursuant to section 402 of the federal Clean Water Act (CWA) and implementing regulations adopted by the U.S. Environmental Protection Agency (U.S. EPA) and chapter 5.5, division 7 of the Water Code (commencing with section 13370). It shall serve as an NPDES permit for point source discharges from this facility to surface waters. This Order also serves as a Master Recycling Permit pursuant to article 4, chapter 7, division 7 of the Water Code (commencing with section 13500).
- B. Background and Rationale for Requirements.** The Central Coast Water Board developed the requirements in this Order based on information submitted as part of the application, through monitoring and reporting programs, and other available information. The Fact Sheet (Attachment F), which contains background information and rationale for the requirements in this Order, is hereby incorporated into and constitutes findings for this Order. Attachments A through E are also incorporated into this Order.
- C. Provisions and Requirements Implementing State Law.** The provisions/requirements in subsections III.B, III.C, and IV.B are included to implement state law only. These provisions/requirements are not required or authorized under the federal CWA; consequently, violations of these provisions/requirements are not subject to the enforcement remedies that are available for NPDES violations.
- D. Notification of Interested Parties.** The Central Coast Water Board has notified the Discharger and interested agencies and persons of its intent to prescribe WDRs for the discharge and has provided them with an opportunity to submit their written comments and recommendations. Details of the notification are provided in the Fact Sheet of this Order.
- E. Consideration of Public Comment.** The Central Coast Water Board, in a public meeting, heard and considered all comments pertaining to the discharge. Details of the Public Hearing are provided in the Fact Sheet of this Order.

**THEREFORE, IT IS HEREBY ORDERED**, that Order No. R3-2010-0012 is rescinded upon the effective date of this Order except for enforcement purposes, and, in order to meet the provisions contained in division 7 of the Water Code (commencing with section 13000) and regulations adopted thereunder and the provisions of the CWA and regulations and guidelines adopted thereunder, the Discharger shall comply with the requirements in this Order. This action in no way prevents the Central Coast Water Board from taking enforcement action for past violations of the previous Order.

### III. DISCHARGE PROHIBITIONS

- F. Discharge of treated wastewater at a location or in a manner other than as described by this Order is prohibited
- G. Discharges of any waste in any manner other than as described by this Order are prohibited.
- H. Effluent average daily dry weather flow shall not exceed 7.64 MGD.
- I. The discharge of any radiological, chemical, or biological warfare agent or high level radioactive waste to the Ocean is prohibited.
- J. The discharge of municipal or industrial waste sludge to the Pacific Ocean is prohibited. The discharge of sludge digester supernatant, without further treatment, directly to the Ocean or to a waste stream that discharges to the Ocean is prohibited.
- K. The overflow of bypass or wastewater from the Discharger's collection, treatment, or disposal facilities and the subsequent discharge of untreated or partially treated wastewater, except as provided for in Attachment D, Standard Provision I.G.a (Bypass), is prohibited.
- L. The discharge of materials and substances in the wastewater that results in any of the following is prohibited:
  - 1. Float or become floatable upon discharge.
  - 2. May form sediments which degrade benthic communities or other aquatic life.
  - 3. Accumulate to toxic levels in marine waters, sediments, or biota.
  - 4. Decrease the natural light to benthic communities and other marine life.
  - 5. Result in aesthetically undesirable discoloration of the ocean surface.

### IV. EFFLUENT LIMITATIONS AND DISCHARGE SPECIFICATIONS

- A. **Final Effluent Limitations – Discharge Point No. 001**
  - 1. **Conventional and Non-Conventional Pollutants**

The Discharger shall maintain compliance with the following effluent limitations at Discharge Point No. 001 with compliance measured at Monitoring Location EFF-001 as described in the attached Monitoring and Reporting Program (MRP).

**Table 4. Effluent Limitations for Conventional and Non-Conventional Pollutants**

Parameter	Units	Effluent Limitations		
		Average Monthly	Average Weekly	Instantaneous Maximum
Biochemical Oxygen Demand 5-day @ 20°C (BOD <sub>5</sub> ) <sup>[1]</sup>	mg/L	30	45	---
	lbs/day <sup>[2]</sup>	1,912	2,867	---
Total Suspended Solids (TSS) <sup>[1]</sup>	mg/L	30	45	---
	lbs/day <sup>[2]</sup>	1,912	2,867	---
Oil and Grease	mg/L	25	40	75
	lbs/day <sup>[2]</sup>	1,590	2,549	4,779
Settleable Solids	mL/L/hr	1.0	1.5	3.0
Turbidity	NTU	75	100	225
pH	standard units	6.0 – 9.0 at all times		

<sup>[1]</sup> The average monthly percent removal for BOD and TSS shall not be less than 85 percent.

<sup>[2]</sup> Mass based effluent limitations were calculated using the following formula:  
 lbs/day = pollutant concentration (mg/L) \* permitted flow (7.64 MGD) \* conversion factor (8.34)

**2. Toxic Pollutants**

The Discharger shall maintain compliance with the following effluent limitations for toxic pollutants at Discharge Point No. 001, with compliance measured at Monitoring Location EFF-001, as described in the attached MRP.

**Table 5. Effluent Limitations – Protection of Marine Aquatic Life**

Parameter	Units	Effluent Limitation		
		6-Mo Median <sup>[1]</sup>	Maximum Daily <sup>[2]</sup>	Instantaneous Maximum <sup>[3]</sup>
Selenium	µg/L	1,845	7,348	18,450
Cyanide <sup>[4]</sup>	µg/L	123	492	1,230
Total Chlorine Residual	µg/L	246	984	7,380
Phenolic Compounds (non-chlorinated)	µg/L	3,690	14,760	36,900
Phenolic Compounds (chlorinated)	µg/L	123	492	1,230
Endosulfan <sup>[5]</sup>	µg/L	1.107	2.214	3.321
Endrin	µg/L	0.246	0.492	0.738
HCH <sup>[6]</sup>	µg/L	0.492	0.984	1.476
Radioactivity		<sup>[7]</sup>		

<sup>[1]</sup> The six-month median shall apply as a moving median of daily values for any 180-day period in which daily values represent flow weighted average concentrations within a 24-hour period. For intermittent discharges, the daily value shall be considered equal to zero for days on which no discharge occurred. The six-month median limit on daily mass emissions shall be determined using the six-month median effluent concentration  $C_e$  and the observed flow rate,  $Q$ , in million gallons per day (MGD).

<sup>[2]</sup> The daily maximum shall apply to flow weighted 24-hour composite samples. The daily maximum mass emission shall be determined using the daily maximum effluent concentration limit as  $C_e$  and the observed flow rate,  $Q$ , in MGD.

<sup>[3]</sup> The instantaneous maximum shall apply to grab sample determinations.

<sup>[4]</sup> If a Discharger can demonstrate to the satisfaction of the Central Coast Water Board (subject to USEPA approval) that an analytical method is available to reliably distinguish between strongly

Parameter	Units	Effluent Limitation		
		6-Mo Median <sup>[1]</sup>	Maximum Daily <sup>[2]</sup>	Instantaneous Maximum <sup>[3]</sup>

and weakly complexed cyanide, effluent limitations for cyanide may be met by the combined measurement of free cyanide, simple alkali metals cyanides, and weakly complexed organometallic cyanide complexes. In order for the analytical method to be acceptable, the recovery of free cyanide from metal complexes must be comparable to that achieved by the approved method in 40 CFR 136.

- <sup>6]</sup> HCH shall mean the sum of the alpha, beta, gamma (lindane) and delta isomers of hexachlorocyclohexane.
- <sup>5]</sup> Endosulfan shall mean the sum of endosulfan-alpha and -beta and endosulfan sulfate.
- <sup>7]</sup> Not to exceed limits specified in Title 17, Division 1, Chapter 5, Subchapter 4, Group 3, Article 3, Section 30253 of the California Code of Regulations

**Table 6. Effluent Limitations – Protection of Human Health – Non-Carcinogens**

Parameter	Units	Effluent Limitation
		30-day Average
Acrolein	µg/L	27,060
Bis(2-chloroethoxy) methane	µg/L	541.2
Bis(2-chloroisopropyl) ether	µg/L	147,600
Chlorobenzene	µg/L	70,110
Di-n-butyl phthalate	µg/L	430,500
Dichlorobenzenes <sup>[1]</sup>	µg/L	627,300
Diethyl phthalate	µg/L	4.06E+06
Dimethyl phthalate	µg/L	1.01E+08
4,6-dinitro-2-methylphenol	µg/L	27,060
2,4-dinitrophenol	µg/L	492
Ethylbenzene	µg/L	504,300
Fluoranthene	µg/L	1,845
Hexachlorocyclopentadiene	µg/L	7,134
Nitrobenzene	µg/L	603
Thallium	µg/L	246
Toluene	µg/L	1.05E+07
Tributyltin	µg/L	0.172
1,1,1-trichloroethane	µg/L	6.64E+07

<sup>[1]</sup> Sum of 1,2- and 1,3-dichlorobenzene.

**Table 7. Effluent Limitations – Protection of Human Health – Carcinogens**

Parameter	Units	Effluent Limitation
		30-day Average
Acrylonitrile	µg/L	12.3
Aldrin	µg/L	0.0027
Benzene	µg/L	725.7
Benzidine	µg/L	0.0085
Beryllium	µg/L	4.059
Bis(2-chloroethyl) ether	µg/L	5.535
Carbon tetrachloride	µg/L	110.7
Chlordane <sup>[1]</sup>	µg/L	0.0028

Parameter	Units	Effluent Limitation
		30-day Average
Chlorodibromomethane	µg/L	1,057
DDT <sup>[2]</sup>	µg/L	0.02091
1,4-dichlorobenzene	µg/L	2,214
3,3-dichlorobenzidine	µg/L	0.9963
1,2-dichloroethane	µg/L	3,444
1,1-dichloroethylene	µg/L	110.7
Dichlorobromomethane	µg/L	762.6
Dichloromethane	µg/L	55,350
1,3-dichloropropene	µg/L	1,094
Dieldrin	µg/L	0.00492
2,4-dinitrotoluene	µg/L	319.8
1,2-diphenylhydrazine	µg/L	19.68
Heptachlor	µg/L	0.00615
Heptachlor epoxide	µg/L	0.00246
Hexachlorobenzene	µg/L	0.02583
Hexachlorobutadiene	µg/L	1,722
Hexachloroethane	µg/L	307.5
Isophorone	µg/L	89,790
N-nitrosodimethylamine	µg/L	897.9
N-nitrosodi-n-propylamine	µg/L	46.74
N-nitrosodiphenylamine	µg/L	307.5
PAHs <sup>[3]</sup>	µg/L	1.0824
PCBs <sup>[4]</sup>	µg/L	0.0023
TCDD equivalents <sup>[5]</sup>	µg/L	4.8E-07
1,1,2,2-tetrachloroethane	µg/L	282.9
Tetrachloroethylene	µg/L	246
Toxaphene	µg/L	0.026
Trichloroethylene	µg/L	3,321
1,1,2-trichloroethane	µg/L	1,156
2,4,6-trichlorophenol	µg/L	36.67
Vinyl chloride	µg/L	4,428



Parameter	Units	Effluent Limitation
		30-day Average

- [1] Sum of chlorodane-alpha, chlorodane-gamma, chlorodene-alpha, chlorodene-gamma, nonachlor-alpha, nonachlor gamma, and oxychlorodane.
- [2] Sum of 4,4'-DDT, 2,4'-DDT, 4,4'-DDE, 2,4'-DDE, 4,4'-DDD, and 2,4'-DDD.
- [3] Sum of acenaphthylene, anthracene, 1,2-benzanthracene, 3,4-benzofluoranthene, benzo[k]fluoranthene, 1,1,2-benzoperylene, benzo[a]pyrene, chrysene, dibenzo[a,h]anthracene, fluorine, ideno[1,2,3-cd]pyrene, phenanthrene, and pyrene.
- [4] Sum of chlorinated biphenyls whose analytical characteristics resemble those of Aroclor-1016, Aroclor-1221, Aroclor-1232, Aroclor-1242, Aroclor-1248, Aroclor-1254, and Aroclor-1260.
- [5] TCDD equivalents shall mean the sum of the concentrations of chlorinated dibenzodioxins (2,3,7,8-CDDs) and chlorinated dibenzofurans (2,3,7,8-CDFs) multiplied by their respective toxicity factors, as shown below :

Isomer Group	Toxicity Equivalent Factor	Isomer Group	Toxicity Equivalent Factor
2,3,7,8-tetra CDD	1.0	1,2,3,7,8-penta CDF	0.05
2,3,7,8-penta CDD	0.5	2,3,4,7,8-penta CDF	0.5
2,3,7,8-hexa CDDs	0.1	2,3,7,8-hexa CDFs	0.1
2,3,7,8-hepta CDD	0.01	2,3,7,8-hepta CDFs	0.01
octa CDD	0.001	octa CDF	0.001
2,3,7,8-tetra CDF	0.1	--	--

**a. Percent Removal**

The average monthly percent removal of BOD<sub>5</sub> and TSS shall not be less than 85 percent.

**b. Bacteria**

The following total coliform, fecal coliform, and enterococcus effluent limits apply if the Executive Officer concludes from a bacterial assessment (described in Receiving Water Limitation A.1) that the discharge consistently exceeds Receiving Water Limitation A.1.

- a. The daily maximum total coliform density shall not exceed 122,000 MPN/100 mL.
- b. The daily maximum fecal coliform density shall not exceed 24,400 MPN/100 mL.
- c. The daily maximum enterococcus density shall not exceed 4,270 MPN/100 mL.

**B. Land Discharge Specifications – Not Applicable**

**C. Recycling Specifications – Discharge Point No. 002**

On September 13, 1991, the Central Coast Water Board adopted Waste Discharge Requirements Order No. 91-03 allowing the Discharger to produce reclaimed water. Since then, the Discharger has used reclaimed water on site. The Goleta Water District, as the primary user of reclaimed water, is responsible for the distribution and use of reclaimed water to the general public under Order No 97-06. The use of reclaimed water may alternatively be regulated by SWRCB General Water Reclamation Requirements for Recycled Water Use.

1. Reclamation use of tertiary treated wastewater shall comply with applicable state and local requirements regarding the production and use of reclaimed wastewater, including requirements of California Water Code (CWC) sections 13500-13577 (Water Reclamation) and Department of Health Services (DHS) regulations at Title 22, sections 60301-60355 of the California Code of Regulations (Water Recycling Criteria).
2. Recycled water production shall comply with a title 22 engineering report approved by the Division of Drinking Water that demonstrates or defines compliance with the Uniform Statewide Recycling Criteria (and amendments).
3. Recycled water shall be disinfected tertiary recycled water, as defined by Title 22, section 60301.230.
4. Recycled water shall be adequately oxidized, filtered, and disinfected, as defined in Title 22.
5. The Discharger shall comply with the following specifications at Discharge Point No. 002 for reclamation of tertiary treated secondary wastewater as described in the attached MRP (Appendix E).
6. The Discharger shall comply with the following specifications at Discharge Point No. 002 for reclamation of tertiary treated secondary wastewater, with compliance measured at Monitoring Location EFF-002, as described in the attached MRP.

Parameter	Units	Effluent Limitations	
		Average Monthly	Maximum Daily
BOD <sub>5</sub>	mg/L	10	25
TSS	mg/L	10	25

7. Recycled water shall not exceed any of the following turbidity limits:
  - a. An average of 2 NTU within a 24-hour period,
  - b. 5 NTU more than 5 percent of the time within a 24-hour period, and
8. The median concentration of total coliform bacteria measured in the disinfected recycled water shall not exceed the following limits:
  - a. An MPN of 2.2 per 100 mL utilizing the bacteriological results of the last seven days for which analyses have been completed,
  - b. An MPN of 23 per 100 mL in more than one sample in any 30 day period, and
  - c. No sample shall exceed an MPN of 240 total coliform bacteria per 100 mL.
9. Recycled water disinfected with chlorine shall have a CT value (chlorine concentration time modal contact time) of not less than 40 mg-min/L at all times with a modal contact time of at least 90 minutes based on a flow of 3.3 MGD.
10. No irrigation use with treated effluent shall take place within 50 feet of any domestic water supply well.
11. No impoundment of treated effluent shall occur within 100 feet of any domestic water supply well.
12. Reclaimed water shall be confined to areas of authorized use without discharge to surface waters or drainage ways.

13. Personnel involved in producing, transporting, or using reclaimed water shall be informed of possible health hazards that may result from contact and use of reclaimed water.
14. Spray irrigation of reclaimed water shall be accomplished at a time and in a manner to minimize ponding and contact with the public.
15. Delivery of reclaimed water shall be discontinued when these Reclamation Specifications cannot be met.
16. All reclamation reservoirs and other areas with public access shall be posted, in English and Spanish, to warn the public that reclaimed wastewater is being stored or used.
17. Reclaimed water systems shall be properly labeled and regularly inspected to ensure proper operation, absence of leaks, and absence of illegal connections.

## V. RECEIVING WATER LIMITATIONS

### A. Surface Water Limitations

The discharge shall not cause a violation of the following receiving water limitations, which are based on water quality objectives contained in the Ocean Plan. Compliance with these limitations shall be determined from effluent sampling showing compliance with comparable effluent standards and limitations.

#### 1. Bacterial Characteristics

- a. Within a zone bounded by the shoreline and a distance of 1,000 feet from the shoreline or the 30-foot depth contour, whichever is further from the shoreline, and in areas outside this zone used for water contact sports, as determined by the Central Coast Water Board (i.e., waters designated REC-1), but including all kelp beds, the following bacterial objectives shall be maintained throughout the water column.

30-day Geometric Mean – The following standards are based on the geometric mean of the five most recent samples from each site:

- i. Total coliform density shall not exceed 1,000 per 100 ml;
- ii. Fecal coliform density shall not exceed 200 per 100 ml; and
- iii. Enterococcus density shall not exceed 35 per 100 ml.

Single Sample Maximum:

- i. Total coliform density shall not exceed 10,000 per 100 ml;
- ii. Fecal coliform density shall not exceed 400 per 100 ml;
- iii. Enterococcus density shall not exceed 104 per 100 ml; and
- iv. Total coliform density shall not exceed 1,000 per 100 ml when the fecal coliform to total coliform ratio exceeds 0.1.

#### b. Shellfish Harvesting Standards

At all areas where shellfish may be harvested for human consumption, as determined by the Central Coast Water Board, the following bacterial objectives shall be maintained throughout the water column.

- i. The median total coliform density shall not exceed 70 per 100 mL, and not more than 10 percent of the samples shall exceed 230 per 100 mL.

**c. Physical Characteristics**

- i. Floating particulates and grease and oil shall not be visible on the ocean surface.
- ii. The discharge of waste shall not cause aesthetically undesirable discoloration of the ocean surface.
- iii. Natural light shall not be significantly reduced at any point outside the zone of initial dilution as the result of the discharge of waste.
- iv. The rate of deposition of inert solids and the characteristics of inert solids in ocean sediments shall not be changed such that benthic communities are degraded.
- v. Temperature of the receiving water shall not be altered to adversely affect beneficial uses, as set forth in the Water Quality Control Plan for Control of Temperature in the Coastal and Interstate Waters and Enclosed Bays and Estuaries of California.

**d. Chemical Characteristics**

- i. The dissolved oxygen concentration shall not, at any time, be depressed more than 10 percent from that which occurs naturally, or fall below 5.0 mg/L.
- ii. The pH shall not be changed at any time more than 0.2 units from that which occurs naturally, and shall be within the range of 7.0 to 8.5 at all times.
- iii. The dissolved sulfide concentrations of waters in and near sediments shall not be significantly increased above that present under natural conditions.
- iv. The concentrations of substances set forth in Table 1 of the Ocean Plan shall not be increased in marine sediments to that which would degrade indigenous biota.
- v. The concentration of organic materials in marine sediments shall not be increased to that which would degrade marine life.
- vi. Nutrient materials shall not cause objectionable aquatic growth or degrade indigenous biota.

**e. Biological Characteristics**

- i. Marine communities, including vertebrate, and plant species, shall not be degraded.
- ii. The natural taste, odor, and color of fish, shellfish, or other marine resources used for human consumption shall not be altered.

- iii. The concentration of organic materials in fish, shellfish, or other marine resources used for human consumption shall not bioaccumulate to levels that are harmful to human health.

**f. Radioactivity**

- i. Discharge of radioactive waste shall not degrade marine life.
- ii. Radionuclides shall not be present in concentrations that are deleterious to human, plant, animal, or aquatic life; or result in the accumulation of radionuclides in the food web to an extent that presents a hazard to human, plant, animal, or aquatic life.

**2. General Standards**

- a. The discharge shall not cause a violation of any applicable WQO or standard for receiving waters adopted by the Central Coast Water Board or State Water Board, as required by the CWA and regulations adopted thereunder.
- b. Waste management systems that discharge to the ocean must be designed and operated in a manner that will maintain the indigenous marine life and a healthy and diverse marine community.
- c. Waste effluents shall be discharged in a manner that provides sufficient initial dilution to minimize the concentrations of substances not removed in the treatment.

**B. Groundwater Limitations – Not Applicable.**

**VI. PROVISIONS**

**A. Standard Provisions**

- 1. **Federal Standard Provisions.** The Discharger shall comply with all Standard Provisions included in Attachment D of this Order.
- 2. **Central Coast Water Board Standard Provisions.** The Discharger shall comply with the Central Coast Water Board Standard Provisions included in Attachment D of this Order.

**B. Monitoring and Reporting Program (MRP) Requirements**

The Discharger shall comply with the MRP, and future revisions thereto, in Attachment E of this Order. All monitoring shall be conducted according to 40 CFR 136, *Guidelines Establishing Test Procedures for Analysis of Pollutants*.

**C. Special Provisions**

**1. Reopener Provisions**

- a. This Order may be reopened and modified in accordance with NPDES regulations at 40 CFR 122 and 124, as necessary, to include additional conditions or limitations based on newly available information or to implement any USEPA approved, new, State WQO.

- b. This Order may be reopened for modification to include an effluent limitation if monitoring establishes that the discharge causes, has the reasonable potential to cause, or contributes to an excursion above a California Ocean Plan (Ocean Plan) Table 1 water quality objective.

## 2. Special Studies, Technical Reports and Additional Monitoring Requirements

The Discharger shall notify the Regional Water Board and USEPA in writing within 14 days of exceedance of a chronic toxicity trigger of 123 TUc. This notification shall describe actions the Discharger has taken or will take to investigate, identify, and correct the causes of toxicity; the status of actions required by this permit; and schedule for actions not yet completed; or reason(s) that no action has been taken.

### a. Toxicity Reduction Requirements

If the discharge consistently exceeds the chronic toxicity trigger of 123 TUc, the Discharger shall conduct a Toxicity Reduction Evaluation (TRE) in accordance with the Discharger's TRE Workplan.

A TRE is a study conducted in a step-wise process designed to identify the causative agents of effluent or ambient toxicity, isolate the sources of toxicity, evaluate the effectiveness of toxicity control options, and then confirm the reduction in toxicity. The first step of the TRE consist of the collection of data relevant to the toxicity, including additional toxicity testing, and an evaluation of facility operations and maintenance practices, and best management practices. A Toxicity Identification Evaluation (TIE) may be required as part of the TRE, if appropriate. A TIE is a set of procedures to identify the specific chemical(s) responsible for toxicity. These procedures are performed in three phases – characterization, identification, and confirmation using aquatic organism's toxicity tests. The TRE shall include all reasonable steps to identify the source of toxicity. The Discharger shall take all reasonable steps to reduce toxicity to the required level once the source of toxicity is identified.

The Discharger shall maintain a TRE Workplan, which describes steps that the Discharger intends to follow in the event that a toxicity trigger established by this Order is exceeded in the discharge. The workplan shall be prepared in accordance with current technical guidance and reference material, including:

- i. Toxicity Reduction Evaluation Guidance for Municipal Wastewater Treatment Plants (EPA/833/B-99-022).
- ii. Toxicity Identification Evaluation, Phase I (EPA/600/6-91/005F).
- iii. Methods for Aquatic Toxicity Identification Evaluations, Phase II (EPA/600/R-92/080).
- iv. Methods for Aquatic Toxicity Identification Evaluations, Phase III (EPA/600/R-92/081).

At a minimum, the TRE Workplan shall include:

- i. Actions that will be taken to investigate/identify the causes/sources of toxicity,

- ii. Actions that will be evaluated to mitigate the impact of the discharge, to correct the non-compliance, and/or to prevent the recurrence of chronic toxicity (this list of action steps may be expanded, if a TRE is undertaken), and
- iii. A schedule under which these actions will be implemented.

When monitoring measures chronic toxicity in the effluent above 123 TUc, the Discharger shall resample immediately, if the discharge is continuing, and retest for chronic toxicity. Results of an initial failed test and results of subsequent monitoring shall be reported to the Executive Officer as soon as possible following receipt of monitoring results, not to exceed 15 days from the conclusion of each test. The Executive Officer will determine whether to initiate enforcement action, whether to require the Discharger to implement a TRE, or to implement other measures. When the Executive Officer requires the Discharger to conduct a TRE, the TRE shall be conducted giving due consideration to guidance provided by the USEPA's *Toxicity Reduction Evaluation Procedures, Phases 1, 2, and 3* (EPA document Nos. EPA 600/R-91/003, 600/6/91/005F, and 600/R-92/080, and 600/R-92/081, respectively). A TRE, if necessary, shall be conducted in accordance with the following schedule.

**Table 8. Toxicity Reduction Evaluation Schedule**

Action Step	When Required
Take all reasonable measures necessary to immediately reduce toxicity, where the source is known.	Within 24 hours of identification of noncompliance.
Initiate the TRE in accordance to the Workplan.	Within 7 days of notification by the Executive Officer.
Conduct the TRE following the procedures in the Workplan.	Within the period specified in the Workplan (not to exceed one year, without an approved Workplan).
Submit the results of the TRE, including summary of findings, required corrective action, and all results and data.	Within 60 days of completion of the TRE.
Implement corrective actions to meet Permit limits and conditions.	To be determined by the Executive Officer.

**b. Initial Investigation TRE Workplan for Whole Effluent Toxicity**

Within 90 days of the permit effective date, the Discharger shall prepare and submit an updated copy of their Initial Investigation Toxicity Reduction Evaluation (TRE) Workplan (1-2 pages) to the Central Coast Water Board for review. This plan shall include steps the Discharger intends to implement if toxicity is measured above a toxicity trigger and should include, at minimum:

- i. A description of the investigation and evaluation techniques that would be used to identify potential causes and sources of toxicity, effluent variability, and treatment system efficiency.
- ii. A description of methods for maximizing in-house treatment system efficiency, good housekeeping practices, and a list of all chemicals used in operations at the facility.
- iii. If a Toxicity Identification Evaluation (TIE) is necessary, an indication if who would conduct the TIEs (i.e., an in-house expert or outside contractor).

This workplan is subject to approval and modification by the Regional Water Board.

- c. Accelerated Toxicity Testing and TRE/TIE Process for Whole Effluent Toxicity
  - i. If the toxicity trigger is exceeded and the source of toxicity is known (e.g., a temporary plant upset), then the Discharger shall conduct one additional toxicity test using the same species and test method. This test shall begin within 14 days of receipt of test results exceeding the toxicity trigger. If the additional toxicity test does not exceed the toxicity effluent trigger, then the Discharger may return to their regular testing frequency.
  - ii. If the toxicity trigger is exceeded and the source of toxicity is not known, then the Discharger shall conduct six additional toxicity tests using the same species and test method, approximately every two weeks, over a 12 week period. This testing shall begin within 14 days of receipt of test results exceeding the toxicity trigger. If none of the additional toxicity tests exceed the toxicity trigger, then the Discharger may return to their regular testing frequency.
  - iii. If one of the additional toxicity tests exceeds the toxicity trigger, then the Discharger shall notify the Executive Officer and Director. If the Executive Officer and Director determine that the discharge consistently exceeds the toxicity trigger, then the Discharger shall initiate a TRE using as guidance the USEPA manuals: Toxicity Reduction Evaluation Guidance for Municipal Wastewater Treatment Plants (EPA 833/B-99/002, 1999) or Generalized Methodology for Conducting Industrial Toxicity Reduction Evaluations (EPN600/2-88/070, 1989). In conjunction, the Discharger shall develop and implement a detailed TRE Workplan which shall include: further actions undertaken by the Discharger to investigate, identify, and correct the causes of toxicity; actions the Discharger will take to mitigate the impact of the discharge and prevent the recurrence of toxicity, and a schedule for these actions. This Detailed TRE Workplan and schedule are subject to approval and modification by the Regional Water Board and USEPA.
  - iv. As part of a TRE, the Discharger may initiate a Toxicity Identification Evaluation (TIE) using the same species and test method, and USEPA TIE guidance manuals-to identify the causes of toxicity. The USEPA TIE guidance manuals are: Toxicity Identification Evaluation: Characterization of Chronically Toxic Effluents, Phase I (EPN600/6-91/005F, 1992; only chronic toxicity); Methods for Aquatic Toxicity Identification Evaluations: Phase I Toxicity Characterization Procedures (EPN600/6-91/003, 1991; only acute toxicity); Methods for Aquatic Toxicity Identification Evaluations, Phase II Toxicity Identification Procedures for Samples Exhibiting Acute and Chronic Toxicity (EPN600/R-92/080, 1993); Methods for Aquatic Toxicity Identification Evaluations, Phase III Toxicity Confirmation Procedures for Samples Exhibiting Acute and Chronic Toxicity (EPN600/R-92/081, 1993); and Marine Toxicity Identification Evaluation (TIE): Phase I Guidance Document (EPN600/R-96-054, 1996).

### **3. Best Management Practices and Pollution Prevention**

#### **a. Pollutant Minimization Program (PMP)**

The Discharger shall develop and conduct a Pollutant Minimization Program (PMP) as further described below when there is evidence (e.g., sample results reported as DNQ when the effluent limitation is less than the MDL, sample results from analytical methods more sensitive than those methods required by this Order,



presence of whole effluent toxicity, health advisories for fish consumption, results of benthic or aquatic organism tissue sampling) that a pollutant is present in the effluent above an effluent limitation and either:

- i. The concentration of the pollutant is reported as DNQ and the effluent limitation is less than the reported ML;
- ii. The concentration of the pollutant is reported as ND and the effluent limitation is less than the MDL, using definitions described in Attachment A and reporting protocols described in MRP section X.B; and
- iii. There is evidence showing that the pollutant is present in the effluent above the calculated effluent limitation. Such evidence may include: health advisories for fish consumption; presence of whole effluent toxicity; results of benthic or aquatic organism tissue sampling; sample results from analytical methods more sensitive than methods included in the permit; and the concentration of the pollutant is reported as DNQ and the effluent limitation is less than the MDL.

The PMP shall include, but not be limited to, the following actions and submittals acceptable to the Central Coast Water Board:

- i. An annual review and semi-annual monitoring of potential sources of the reportable pollutant(s), which may include fish tissue monitoring and other bio-uptake sampling;
- ii. Quarterly monitoring for the reportable pollutant(s) in the influent to the wastewater treatment system;
- iii. Submittal of a control strategy designed to proceed toward the goal of maintaining concentrations of the reportable pollutant(s) in the effluent at or below the effluent limitation;
- iv. Implementation of appropriate cost-effective control measures for the reportable pollutant(s), consistent with the control strategy; and
- v. An annual status report that shall be sent to the Central Coast Water Board including:
  - (a) All PMP monitoring results for the previous year;
  - (b) A list of potential sources of the reportable pollutant(s);
  - (c) A summary of all actions undertaken pursuant to the control strategy; and
  - (d) A description of actions to be taken in the following year.

**4. Construction, Operation and Maintenance Specifications – Not Applicable**

**5. Special Provisions for Municipal Facilities (POTWs Only)**

- a. **Biosolids Management.** Provisions regarding sludge handling and disposal ensure that such activity will comply with all applicable regulations.

40 CFR Part 503 sets forth USEPA's final rule for the use and disposal of biosolids, or sewage sludge, and governs the final use or disposal of biosolids. The intent of this federal program is to ensure that sewage sludge is used or disposed of in a way that protects both human health and the environment.

USEPA's regulations require that producers of sewage sludge meet certain reporting, handling, and disposal requirements. As the USEPA has not delegated the authority to implement the sludge program to the State of California, the enforcement of sludge requirements that apply to the Discharger remains under USEPA's jurisdiction at this time. USEPA, not the Regional Water Board, will oversee compliance with 40 CFR Part 503.

- b. Pretreatment.** Pretreatment requirements for POTWs are contained within 40 CFR Part 403. Per 40 CFR Part 403.8, any POTW (or combination of POTWs operated by the same authority) with a total design flow greater than 5 million gallons per day (MGD) and receiving from industrial users pollutants which pass through or interfere with the operation of the POTW or are otherwise subject to pretreatment standards will be required to establish a POTW pretreatment program unless the NPDES State exercises its option to assume local responsibilities as provided for in §403.1 O(e). The Executive Officer may require that a POTW with a design flow of 5 MDG or less develop a POTW pretreatment program if he or she finds that the nature or volume of the industrial influent, treatment process upsets, violations of POTW effluent limitations, contamination of municipal sludge, or other circumstances warrant in order to prevent interference with the POTW or pass through as defined in 40 CFR Part 403.3.

## 6. Other Special Provisions

- a. Discharges of Storm Water.** Discharges of storm water from POTWs with a design capacity greater than 1.0 MGD are applicable for coverage under General State Water Board Order No. 2014-0057-DWQ, NPDES General Permit No. CAS000001 *Waste Discharge Requirements for Dischargers of Storm Water Associated with Industrial Activities Excluding Construction Activities.*
- b. Sanitary Sewer System Requirements.** The State Water Board has adopted a Statewide general permit for the regulation of the operation, maintenance, and monitoring of collection systems. This Order requires coverage by and compliance with applicable provisions of General Waste Discharge Requirements for Sanitary Sewer Systems (State Water Board Order No. 2006-0003-DWQ). This General Permit, adopted on May 2, 2006, is applicable to all "federal and state agencies, municipalities, counties, districts, and other public entities that own or operate sanitary sewer systems greater than one mile in length that collect and/or convey untreated or partially treated wastewater to a publicly owned treatment facility in the State of California." In July 2013, the State Water Board revised the monitoring and reporting program (WQ 2013-0058-EXEC). The purpose of the General Permit is to promote the proper and efficient management, operation, and maintenance of sanitary sewer systems and to minimize the occurrences and impacts of sanitary sewer overflows. The Discharger is enrolled under the General Permit.

## 7. Compliance Schedules – Not Applicable

## VII. COMPLIANCE DETERMINATION

### A. General

Compliance with effluent limitations for reportable pollutants shall be determined using sample reporting protocols defined in the MRP and Attachment A of this Order. For purposes of reporting and administrative enforcement by the Central Coast and State Water Boards, the Discharger shall be deemed out of compliance with effluent limitations if the concentration of the reportable pollutant in the monitoring sample is greater than the effluent limitation and greater than or equal to the reported Minimum Level (ML).

### B. Multiple Sample Data

When determining compliance with a measure of central tendency (arithmetic mean, geometric mean, median, etc.) of multiple samples analyses and the data set contains one or more reported determinations of "Detected, but Not Quantified" ("DNQ", or "Not Detected" (ND), the Discharger shall compute the median in place of the arithmetic mean in accordance with the following procedure:

1. The data set shall be ranked from low to high, ranking the reported ND determinations lowest, DNQ determinations next, followed by quantified values (if any). The order of the individual ND or DNQ determinations is unimportant.
2. The median value of the data set shall be determined. If the data set has an odd number of data points, then the median is the middle value. If the data set has an even number of data points, then the median is the average of the two values around the middle unless one or both of the points are ND or DNQ, in which case the median value shall be the lower of the two data points where DNQ is lower than a value and ND is lower than DNQ.

### C. Average Monthly Effluent Limitation (AMEL)

If the average of daily discharges over a calendar month exceeds the AMEL for a given parameter, an alleged violation will be flagged and the Discharger will be considered out of compliance for each day of that month for that parameter (e.g., resulting in 31 days of non-compliance in a 31-day month). The average of daily discharges over the calendar month that exceeds the AMEL for a parameter will be considered out of compliance for that month only. If only a single sample is taken during the calendar month and the analytical result for that sample exceeds the AMEL, the Discharger will be considered out of compliance for that calendar month. For any one calendar month during which no sample (daily discharge) is taken, no compliance determination can be made for that calendar month.

### D. Average Weekly Effluent Limitation (AWEL)

If the average of daily discharges over a calendar week exceeds the AWEL for a given parameter, an alleged violation will be flagged and the Discharger will be considered out of compliance for each day of that week for that parameter, resulting in 7 days of non-compliance. The average of daily discharges over the calendar week that exceeds the AWEL for a parameter will be considered out of compliance for that week only. If only a single sample is taken during the calendar week and the analytical result for that sample exceeds the AWEL, the Discharger will be considered out of compliance for that calendar week. For

any one calendar week during which no sample (daily discharge) is taken, no compliance determination can be made for that calendar week.

**E. Maximum Daily Effluent Limitation (MDEL)**

If a daily discharge exceeds the MDEL for a given parameter, an alleged violation will be flagged and the Discharger will be considered out of compliance for that parameter for that 1 day only within the reporting period. For any 1 day during which no sample is taken, no compliance determination can be made for that day.

## ATTACHMENT A – DEFINITIONS

### Acute Toxicity

- a. Acute Toxicity (TUa)  
Expressed in Toxic Units Acute (TUa)

$$TUa = \frac{100}{96\text{-hr LC } 50\%}$$

- b. Lethal Concentration 50% (LC 50)

LC 50 (percent waste giving 50% survival of test organisms) shall be determined by static or continuous flow bioassay techniques using standard marine test species as specified in Ocean Plan Appendix III. If specific identifiable substances in wastewater can be demonstrated by the discharger as being rapidly rendered harmless upon discharge to the marine environment, but not as a result of dilution, the LC 50 may be determined after the test samples are adjusted to remove the influence of those substances.

When it is not possible to measure the 96-hour LC 50 due to greater than 50 percent survival of the test species in 100 percent waste, the toxicity concentration shall be calculated by the expression:

$$TUa = \frac{\log(100 - S)}{1.7}$$

where:

S = percentage survival in 100% waste. If S > 99, TUa shall be reported as zero.

### Areas of Special Biological Significance (ASBS)

Those areas designated by the State Water Board as ocean areas requiring protection of species or biological communities to the extent that alteration of natural water quality is undesirable. All Areas of Special Biological Significance are also classified as a subset of STATE WATER QUALITY PROTECTION AREAS.

### Average Monthly Effluent Limitation (AMEL)

The highest allowable average of daily discharges over a calendar month, calculated as the sum of all daily discharges measured during a calendar month divided by the number of daily discharges measured during that month.

### Average Weekly Effluent Limitation (AWEL)

The highest allowable average of daily discharges over a calendar week (Sunday through Saturday), calculated as the sum of all daily discharges measured during a calendar week divided by the number of daily discharges measured during that week.

### Chlordane

Shall mean the sum of chlordane-alpha, chlordane-gamma, chlordene-alpha, chlordene-gamma, nonachlor-alpha, nonachlor-gamma, and oxychlordane.

### **Chronic Toxicity**

This parameter shall be used to measure the acceptability of waters for supporting a healthy marine biota until improved methods are developed to evaluate biological response.

- a. Chronic Toxicity (TUc)  
Expressed as Toxic Units Chronic (TUc)

$$TUc = \frac{100}{NOEL}$$

- b. No Observed Effect Level (NOEL)

The NOEL is expressed as the maximum percent effluent or receiving water that causes no observable effect on a test organism, as determined by the result of a critical life stage toxicity test listed in Ocean Plan Appendix II.

### **Daily Discharge**

Daily Discharge is defined as either: (1) the total mass of the constituent discharged over the calendar day (12:00 am through 11:59 pm) or any 24-hour period that reasonably represents a calendar day for purposes of sampling (as specified in the permit), for a constituent with limitations expressed in units of mass or; (2) the unweighted arithmetic mean measurement of the constituent over the day for a constituent with limitations expressed in other units of measurement (e.g., concentration).

The daily discharge may be determined by the analytical results of a composite sample taken over the course of one day (a calendar day or other 24-hour period defined as a day) or by the arithmetic mean of analytical results from one or more grab samples taken over the course of the day.

For composite sampling, if 1 day is defined as a 24-hour period other than a calendar day, the analytical result for the 24-hour period will be considered as the result for the calendar day in which the 24-hour period ends.

### **DDT**

Shall mean the sum of 4,4'DDT, 2,4'DDT, 4,4'DDE, 2,4'DDE, 4,4'DDD, and 2,4'DDD.

### **Degrade**

Degradation shall be determined by comparison of the waste field and reference site(s) for characteristic species diversity, population density, contamination, growth anomalies, debility, or supplanting of normal species by undesirable plant and animal species. Degradation occurs if there are significant differences in any of three major biotic groups, namely, demersal fish, benthic invertebrates, or attached algae. Other groups may be evaluated where benthic species are not affected, or are not the only ones affected.

### **Detected, but Not Quantified (DNQ)**

Sample results that are less than the reported Minimum Level, but greater than or equal to the laboratory's MDL. Sample results reported as DNQ are estimated concentrations.

### **Dichlorobenzenes**

Shall mean the sum of 1,2- and 1,3-dichlorobenzene.

### **Downstream Ocean Waters**

Waters downstream with respect to ocean currents.

**Dredged Material**

Any material excavated or dredged from the navigable waters of the United States, including material otherwise referred to as “spoil.”

**Enclosed Bays**

Indentations along the coast that enclose an area of oceanic water within distinct headlands or harbor works. Enclosed bays include all bays where the narrowest distance between headlands or outermost harbor works is less than 75 percent of the greatest dimension of the enclosed portion of the bay. This definition includes but is not limited to: Humboldt Bay, Bodega Harbor, Tomales Bay, Drakes Estero, San Francisco Bay, Morro Bay, Los Angeles Harbor, Upper and Lower Newport Bay, Mission Bay, and San Diego Bay.

**Endosulfan**

The sum of endosulfan-alpha and -beta and endosulfan sulfate.

**Estuaries and Coastal Lagoons** are waters at the mouths of streams that serve as mixing zones for fresh and ocean waters during a major portion of the year. Mouths of streams that are temporarily separated from the ocean by sandbars shall be considered as estuaries. Estuarine waters will generally be considered to extend from a bay or the open ocean to the upstream limit of tidal action but may be considered to extend seaward if significant mixing of fresh and salt water occurs in the open coastal waters. The waters described by this definition include but are not limited to the Sacramento-San Joaquin Delta as defined by Section 12220 of the California Water Code, Suisun Bay, Carquinez Strait downstream to Carquinez Bridge, and appropriate areas of the Smith, Klamath, Mad, Eel, Noyo, and Russian Rivers.

**Halomethanes** shall mean the sum of bromoform, bromomethane (methyl bromide) and chloromethane (methyl chloride).

**HCH** shall mean the sum of the alpha, beta, gamma (lindane) and delta isomers of hexachlorocyclohexane.

**Initial Dilution**

The process that results in the rapid and irreversible turbulent mixing of wastewater with ocean water around the point of discharge.

For a submerged buoyant discharge, characteristic of most municipal and industrial wastes that are released from the submarine outfalls, the momentum of the discharge and its initial buoyancy act together to produce turbulent mixing. Initial dilution in this case is completed when the diluting wastewater ceases to rise in the water column and first begins to spread horizontally.

For shallow water submerged discharges, surface discharges, and non-buoyant discharges, characteristic of cooling water wastes and some individual discharges, turbulent mixing results primarily from the momentum of discharge. Initial dilution, in these cases, is considered to be completed when the momentum induced velocity of the discharge ceases to produce significant mixing of the waste, or the diluting plume reaches a fixed distance from the discharge to be specified by the Regional Board, whichever results in the lower estimate for initial dilution.

**Instantaneous Maximum Effluent Limitation**

The highest allowable value for any single grab sample or aliquot (i.e., each grab sample or aliquot is independently compared to the instantaneous maximum limitation).

**Instantaneous Minimum Effluent Limitation**

The lowest allowable value for any single grab sample or aliquot (i.e., each grab sample or aliquot is independently compared to the instantaneous minimum limitation).

**Kelp Beds**

For purposes of the bacteriological standards of the Ocean Plan, are significant aggregations of marine algae of the genera Macrocytis and Nereocystis. Kelp beds include the total foliage canopy of Macrocytis and Nereocystis plants throughout the water column.

**Mariculture**

The culture of plants and animals in marine waters independent of any pollution source.

**Material**

(a) In common usage: (1) the substance or substances of which a thing is made or composed (2) substantial; (b) For purposes of the Ocean Plan relating to waste disposal, dredging and the disposal of dredged material and fill, MATERIAL means matter of any kind or description which is subject to regulation as waste, or any material dredged from the navigable waters of the United States. See also, DREDGED MATERIAL.

**Maximum Daily Effluent Limitation (MDEL)**

The highest allowable daily discharge of a pollutant.

**Method Detection Limit (MDL)**

MDL is defined as the minimum concentration of a substance that can be reported with 99% confidence that the measured concentration is distinguishable from method blank results, as defined in 40 C.F.R. part 136, Attachment B.

**Minimum Level (ML)**

The concentration at which the entire analytical system must give a recognizable signal and acceptable calibration point. The ML is the concentration in a sample that is equivalent to the concentration of the lowest calibration standard analyzed by a specific analytical procedure, assuming that all the method specified sample weights, volumes, and processing steps have been followed.

**Natural Light**

Reduction of natural light may be determined by the Central Coast Water Board by measurement of light transmissivity or total irradiance, or both, according to the monitoring needs of the Central Coast Water Board.

**Not Detected (ND)**

Those sample results less than the laboratory's MDL.

**Ocean Waters**

The territorial marine waters of the state as defined by California law to the extent these waters are outside of enclosed bays, estuaries, and coastal lagoons. If a discharge outside the territorial waters of the state could affect the quality of the waters of the state, the discharge may be regulated to assure no violation of the Ocean Plan will occur in ocean waters.

**PAHs (polynuclear aromatic hydrocarbons)**

The sum of acenaphthylene, anthracene, 1,2-benzanthracene, 3,4-benzofluoranthene, benzo[k]fluoranthene, 1,12-benzoperylene, benzo[a]pyrene, chrysene, dibenzo[ah]anthracene, fluorene, indeno[1,2,3-cd]pyrene, phenanthrene and pyrene.



**PCBs (polychlorinated biphenyls)**

The sum of chlorinated biphenyls whose analytical characteristics resemble those of Aroclor-1016, Aroclor-1221, Aroclor-1232, Aroclor-1242, Aroclor-1248, Aroclor-1254 and Aroclor-1260.

**Pollutant Minimization Program (PMP)**

PMP means waste minimization and pollution prevention actions that include, but are not limited to, product substitution, waste stream recycling, alternative waste management methods, and education of the public and businesses. The goal of the PMP shall be to reduce all potential sources of Ocean Plan Table 1 pollutants through pollutant minimization (control) strategies, including pollution prevention measures as appropriate, to maintain the effluent concentration at or below the water quality-based effluent limitation. Pollution prevention measures may be particularly appropriate for persistent bioaccumulative priority pollutants where there is evidence that beneficial uses are being impacted. The Central Coast Water Board may consider cost effectiveness when establishing the requirements of a PMP. The completion and implementation of a Pollution Prevention Plan, if required pursuant to Water Code section 13263.3(d), shall be considered to fulfill the PMP requirements.

**Reported Minimum Level**

The reported ML (also known as the Reporting Level or RL) is the ML (and its associated analytical method) chosen by the Discharger for reporting and compliance determination from the MLs included in this Order, including an additional factor if applicable as discussed herein. The MLs included in this Order correspond to approved analytical methods for reporting a sample result that are selected by the Central Coast Water Board either from Appendix II of the Ocean Plan in accordance with section III.C.5.a. of the Ocean Plan or established in accordance with section III.C.5.b. of the Ocean Plan. The ML is based on the proper application of method-based analytical procedures for sample preparation and the absence of any matrix interferences. Other factors may be applied to the ML depending on the specific sample preparation steps employed. For example, the treatment typically applied in cases where there are matrix-effects is to dilute the sample or sample aliquot by a factor of ten. In such cases, this additional factor must be applied to the ML in the computation of the reported ML.

**Satellite Collection System**

The portion, if any, of a sanitary sewer system owned or operated by a different public agency than the agency that owns and operates the wastewater treatment facility that a sanitary sewer system is tributary to.

**Shellfish**

Organisms identified by the California Department of Health Services as shellfish for public health purposes (i.e., mussels, clams and oysters).

**Significant Difference**

Defined as a statistically significant difference in the means of two distributions of sampling results at the 95 percent confidence level.

**Six-Month Median Effluent Limitation**

The highest allowable moving median of all daily discharges for any 180-day period.

**State Water Quality Protection Areas (SWQPAs)**

Non-terrestrial marine or estuarine areas designated to protect marine species or biological communities from an undesirable alteration in natural water quality. All AREAS OF SPECIAL BIOLOGICAL SIGNIFICANCE (ASBS) that were previously designated by the State Water Board in Resolution Nos. 74-28, 74-32, and 75-61 are now also classified as a subset of State Water Quality Protection Areas and require special protections afforded by the Ocean Plan.

**TCDD Equivalents**

The sum of the concentrations of chlorinated dibenzodioxins (2,3,7,8-CDDs) and chlorinated dibenzofurans (2,3,7,8-CDFs) multiplied by their respective toxicity factors, as shown in the table below.

Isomer Group	Toxicity Equivalence Factor
2,3,7,8-tetra CDD	1.0
2,3,7,8-penta CDD	0.5
2,3,7,8-hexa CDDs	0.1
2,3,7,8-hepta CDD	0.01
octa CDD	0.001
2,3,7,8 tetra CDF	0.1
1,2,3,7,8 penta CDF	0.05
2,3,4,7,8 penta CDF	0.5
2,3,7,8 hexa CDFs	0.1
2,3,7,8 hepta CDFs	0.01
octa CDF	0.001

**Toxicity Reduction Evaluation (TRE)**

A study conducted in a step-wise process designed to identify the causative agents of effluent or ambient toxicity, isolate the sources of toxicity, evaluate the effectiveness of toxicity control options, and then confirm the reduction in toxicity. The first steps of the TRE consist of the collection of data relevant to the toxicity, including additional toxicity testing, and an evaluation of facility operations and maintenance practices, and best management practices. A Toxicity Identification Evaluation (TIE) may be required as part of the TRE, if appropriate. (A TIE is a set of procedures to identify the specific chemical(s) responsible for toxicity. These procedures are performed in three phases (characterization, identification, and confirmation) using aquatic organism toxicity tests.)

**Waste**

As used in the Ocean Plan, waste includes a Discharger’s total discharge, of whatever origin, i.e., gross, not net, discharge.

**Water Recycling**

The treatment of wastewater to render it suitable for reuse, the transportation of treated wastewater to the place of use, and the actual use of treated wastewater for a direct beneficial use or controlled use that would not otherwise occur.

ATTACHMENT B – MAP



ATTACHMENT C – FLOW SCHEMATIC

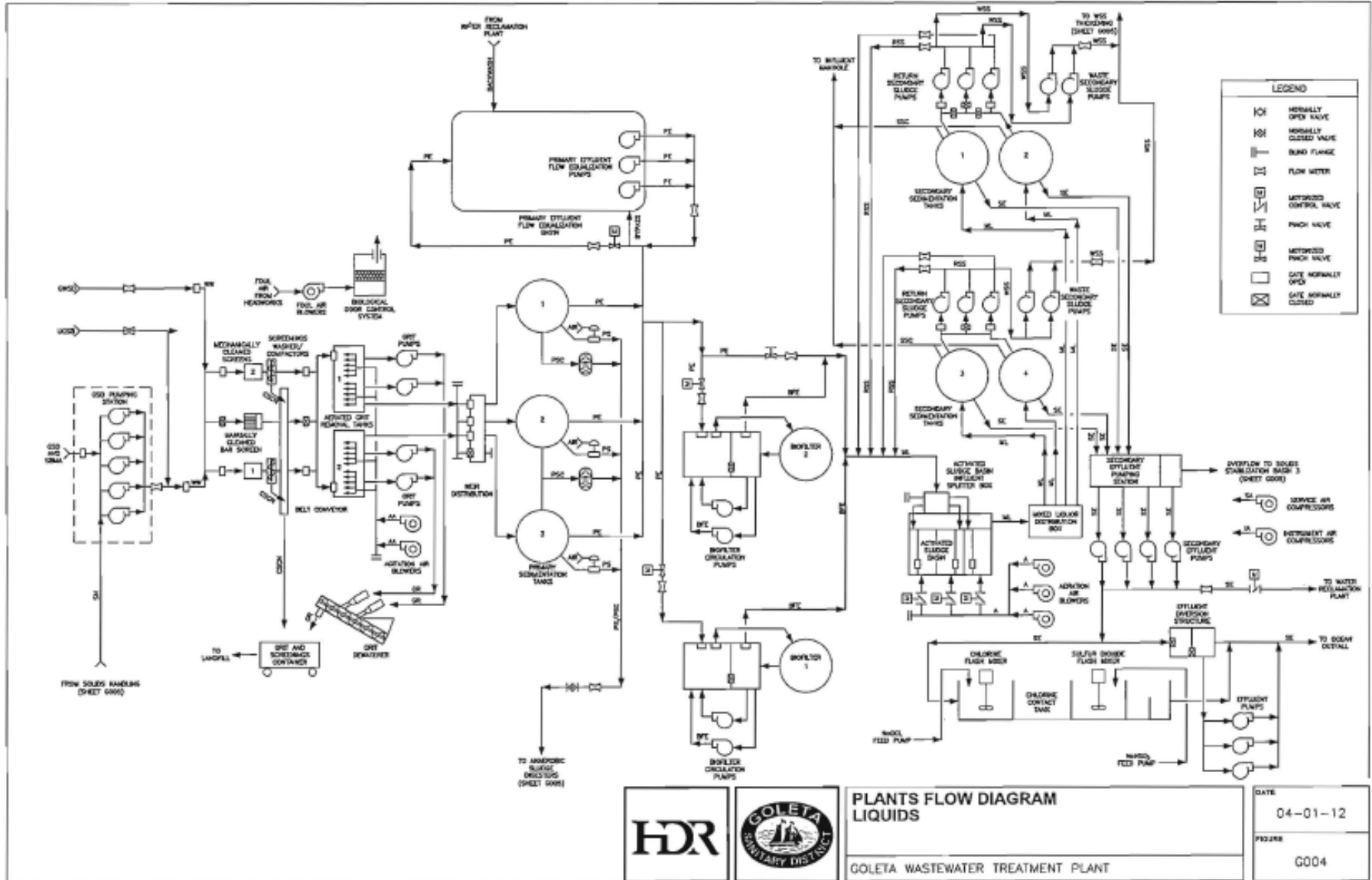

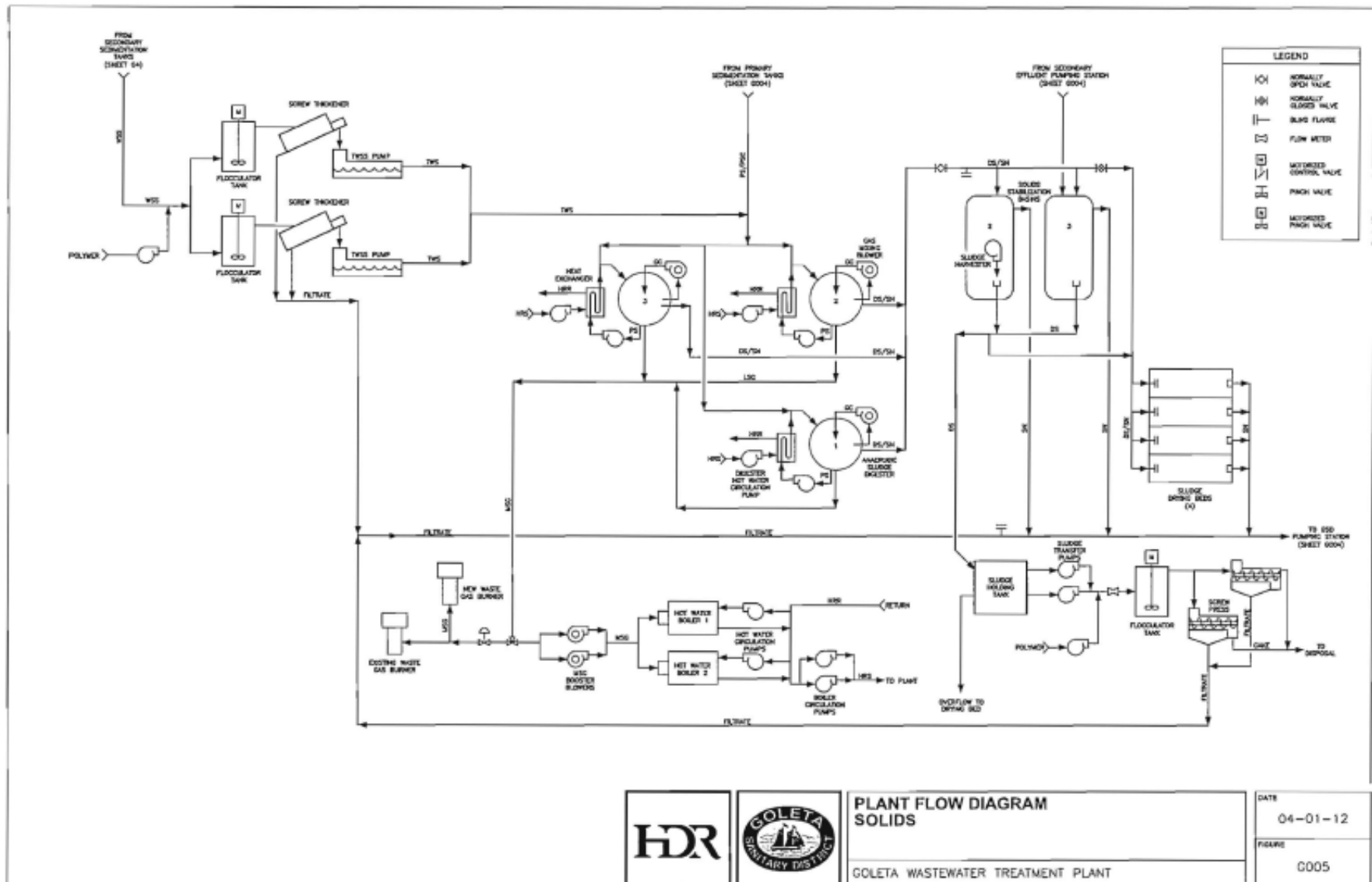

## ATTACHMENT D – STANDARD PROVISIONS

### I. STANDARD PROVISIONS – PERMIT COMPLIANCE

#### A. Duty to Comply

1. The Discharger must comply with all of the conditions of this Order. Any noncompliance constitutes a violation of the Clean Water Act (CWA) and the California Water Code and is grounds for enforcement action, for permit termination, revocation and reissuance, or modification; or denial of a permit renewal application. (40 C.F.R. § 122.41(a).)
2. The Discharger shall comply with effluent standards or prohibitions established under Section 307(a) of the CWA for toxic pollutants and with standards for sewage sludge use or disposal established under Section 405(d) of the CWA within the time provided in the regulations that establish these standards or prohibitions, even if this Order has not yet been modified to incorporate the requirement. (40 C.F.R. § 122.41(a)(1).)

#### B. Need to Halt or Reduce Activity Not a Defense

It shall not be a defense for a Discharger in an enforcement action that it would have been necessary to halt or reduce the permitted activity in order to maintain compliance with the conditions of this Order. (40 C.F.R. § 122.41(c).)

#### C. Duty to Mitigate

The Discharger shall take all reasonable steps to minimize or prevent any discharge or sludge use or disposal in violation of this Order that has a reasonable likelihood of adversely affecting human health or the environment. (40 C.F.R. § 122.41(d).)

#### D. Proper Operation and Maintenance

The Discharger shall at all times properly operate and maintain all facilities and systems of treatment and control (and related appurtenances) which are installed or used by the Discharger to achieve compliance with the conditions of this Order. Proper operation and maintenance also includes adequate laboratory controls and appropriate quality assurance procedures. This provision requires the operation of backup or auxiliary facilities or similar systems that are installed by a Discharger only when necessary to achieve compliance with the conditions of this Order. (40 C.F.R. § 122.41(e).)

#### E. Property Rights

1. This Order does not convey any property rights of any sort or any exclusive privileges. (40 C.F.R. § 122.41(g).)
2. The issuance of this Order does not authorize any injury to persons or property or invasion of other private rights, or any infringement of state or local law or regulations. (40 C.F.R. § 122.5(c).)

## **F. Inspection and Entry**

The Discharger shall allow the Central Coast Water Board, State Water Board, U.S. EPA, and/or their authorized representatives (including an authorized contractor acting as their representative), upon the presentation of credentials and other documents, as may be required by law, to (40 C.F.R. § 122.41(i); Wat. Code, § 13383):

1. Enter upon the Discharger's premises where a regulated facility or activity is located or conducted, or where records are kept under the conditions of this Order (40 C.F.R. § 122.41(i)(1));
2. Have access to and copy, at reasonable times, any records that must be kept under the conditions of this Order (40 C.F.R. § 122.41(i)(2));
3. Inspect and photograph, at reasonable times, any facilities, equipment (including monitoring and control equipment), practices, or operations regulated or required under this Order (40 C.F.R. § 122.41(i)(3)); and
4. Sample or monitor, at reasonable times, for the purposes of assuring Order compliance or as otherwise authorized by the CWA or the Water Code, any substances or parameters at any location. (40 C.F.R. § 122.41(i)(4).)

## **G. Bypass**

1. Definitions
  - a. "Bypass" means the intentional diversion of waste streams from any portion of a treatment facility. (40 C.F.R. § 122.41(m)(1)(i).)
  - b. "Severe property damage" means substantial physical damage to property, damage to the treatment facilities, which causes them to become inoperable, or substantial and permanent loss of natural resources that can reasonably be expected to occur in the absence of a bypass. Severe property damage does not mean economic loss caused by delays in production. (40 C.F.R. § 122.41(m)(1)(ii).)
2. Bypass not exceeding limitations. The Discharger may allow any bypass to occur which does not cause exceedances of effluent limitations, but only if it is for essential maintenance to assure efficient operation. These bypasses are not subject to the provisions listed in Standard Provisions – Permit Compliance I.G.3, I.G.4, and I.G.5 below. (40 C.F.R. § 122.41(m)(2).)
3. Prohibition of bypass. Bypass is prohibited, and the Central Coast Water Board may take enforcement action against a Discharger for bypass, unless (40 C.F.R. § 122.41(m)(4)(i)):
  - a. Bypass was unavoidable to prevent loss of life, personal injury, or severe property damage (40 C.F.R. § 122.41(m)(4)(i)(A));
  - c. There were no feasible alternatives to the bypass, such as the use of auxiliary treatment facilities, retention of untreated wastes, or maintenance during normal periods of equipment downtime. This condition is not satisfied if adequate back-up equipment should have been installed in the exercise of reasonable engineering

judgment to prevent a bypass that occurred during normal periods of equipment downtime or preventive maintenance (40 C.F.R. § 122.41(m)(4)(i)(B)); and

- d. The Discharger submitted notice to the Central Coast Water Board as required under Standard Provisions – Permit Compliance I.G.5 below. (40 C.F.R. § 122.41(m)(4)(i)(C).)
4. The Central Coast Water Board may approve an anticipated bypass, after considering its adverse effects, if the Central Coast Water Board determines that it will meet the three conditions listed in Standard Provisions – Permit Compliance I.G.3 above. (40 C.F.R. § 122.41(m)(4)(ii).)
5. Notice
  - a. Anticipated bypass. If the Discharger knows in advance of the need for a bypass, it shall submit a notice, if possible at least 10 days before the date of the bypass. (40 C.F.R. § 122.41(m)(3)(i).)
  - e. Unanticipated bypass. The Discharger shall submit notice of an unanticipated bypass as required in Standard Provisions - Reporting V.E below (24-hour notice). (40 C.F.R. § 122.41(m)(3)(ii).)

#### **H. Upset**

Upset means an exceptional incident in which there is unintentional and temporary noncompliance with technology based permit effluent limitations because of factors beyond the reasonable control of the Discharger. An upset does not include noncompliance to the extent caused by operational error, improperly designed treatment facilities, inadequate treatment facilities, lack of preventive maintenance, or careless or improper operation. (40 C.F.R. § 122.41(n)(1).)

1. Effect of an upset. An upset constitutes an affirmative defense to an action brought for noncompliance with such technology based permit effluent limitations if the requirements of Standard Provisions – Permit Compliance I.H.2 below are met. No determination made during administrative review of claims that noncompliance was caused by upset, and before an action for noncompliance, is final administrative action subject to judicial review. (40 C.F.R. § 122.41(n)(2).)
2. Conditions necessary for a demonstration of upset. A Discharger who wishes to establish the affirmative defense of upset shall demonstrate, through properly signed, contemporaneous operating logs or other relevant evidence that (40 C.F.R. § 122.41(n)(3)):
  - a. An upset occurred and that the Discharger can identify the cause(s) of the upset (40 C.F.R. § 122.41(n)(3)(i));
  - f. The permitted facility was, at the time, being properly operated (40 C.F.R. § 122.41(n)(3)(ii));
  - g. The Discharger submitted notice of the upset as required in Standard Provisions – Reporting V.E.2.b below (24-hour notice) (40 C.F.R. § 122.41(n)(3)(iii)); and
  - h. The Discharger complied with any remedial measures required under Standard Provisions – Permit Compliance I.C above. (40 C.F.R. § 122.41(n)(3)(iv).)



3. Burden of proof. In any enforcement proceeding, the Discharger seeking to establish the occurrence of an upset has the burden of proof. (40 C.F.R. § 122.41(n)(4).)

## II. STANDARD PROVISIONS – PERMIT ACTION

### A. General

This Order may be modified, revoked and reissued, or terminated for cause. The filing of a request by the Discharger for modification, revocation and reissuance, or termination, or a notification of planned changes or anticipated noncompliance does not stay any Order condition. (40 C.F.R. § 122.41(f).)

### B. Duty to Reapply

If the Discharger wishes to continue an activity regulated by this Order after the expiration date of this Order, the Discharger must apply for and obtain a new permit. (40 C.F.R. § 122.41(b).)

### C. Transfers

This Order is not transferable to any person except after notice to the Central Coast Water Board. The Central Coast Water Board may require modification or revocation and reissuance of the Order to change the name of the Discharger and incorporate such other requirements as may be necessary under the CWA and the Water Code. (40 C.F.R. § 122.41(l)(3); § 122.61.)

## III. STANDARD PROVISIONS – MONITORING

- A. Samples and measurements taken for the purpose of monitoring shall be representative of the monitored activity. (40 C.F.R. § 122.41(j)(1).)
- B. Monitoring results must be conducted according to test procedures under 40 C.F.R. part 136 or, in the case of sludge use or disposal, approved under 40 C.F.R. part 136 unless otherwise specified in 40 C.F.R. part 503 unless other test procedures have been specified in this Order. (40 C.F.R. § 122.41(j)(4); § 122.44(i)(1)(iv).)

## IV. STANDARD PROVISIONS – RECORDS

- A. Except for records of monitoring information required by this Order related to the Discharger's sewage sludge use and disposal activities, which shall be retained for a period of at least five years (or longer as required by 40 C.F.R. part 503), the Discharger shall retain records of all monitoring information, including all calibration and maintenance records and all original strip chart recordings for continuous monitoring instrumentation, copies of all reports required by this Order, and records of all data used to complete the application for this Order, for a period of at least three (3) years from the date of the sample, measurement, report or application. This period may be extended by request of the Central Coast Water Board Executive Officer at any time. (40 C.F.R. § 122.41(j)(2).)
- C. Records of monitoring information shall include:
  1. The date, exact place, and time of sampling or measurements (40 C.F.R. § 122.41(j)(3)(i));

2. The individual(s) who performed the sampling or measurements (40 C.F.R. § 122.41(j)(3)(ii));
3. The date(s) analyses were performed (40 C.F.R. § 122.41(j)(3)(iii));
4. The individual(s) who performed the analyses (40 C.F.R. § 122.41(j)(3)(iv));
5. The analytical techniques or methods used (40 C.F.R. § 122.41(j)(3)(v)); and
6. The results of such analyses. (40 C.F.R. § 122.41(j)(3)(vi).)

**D. Claims of confidentiality for the following information will be denied (40 C.F.R. § 122.7(b)):**

1. The name and address of any permit applicant or Discharger (40 C.F.R. § 122.7(b)(1)); and
2. Permit applications and attachments, permits and effluent data. (40 C.F.R. § 122.7(b)(2).)

**V. STANDARD PROVISIONS – REPORTING**

**A. Duty to Provide Information**

The Discharger shall furnish to the Central Coast Water Board State Water Board, or U.S. EPA within a reasonable time, any information which the Central Coast Water Board, State Water Board, or U.S. EPA may request to determine whether cause exists for modifying, revoking and reissuing, or terminating this Order or to determine compliance with this Order. Upon request, the Discharger shall also furnish to the Central Coast Water Board, State Water Board, or U.S. EPA copies of records required to be kept by this Order. (40 C.F.R. § 122.41(h); Wat. Code, § 13267.)

**B. Signatory and Certification Requirements**

1. All applications, reports, or information submitted to the Central Coast Water Board, State Water Board, and/or U.S. EPA shall be signed and certified in accordance with Standard Provisions – Reporting V.B.2, V.B.3, V.B.4, and V.B.5 below. (40 C.F.R. § 122.41(k).)
2. All permit applications shall be signed by either a principal executive officer or ranking elected official. For purposes of this provision, a principal executive officer of a federal agency includes: (i) the chief executive officer of the agency, or (ii) a senior executive officer having responsibility for the overall operations of a principal geographic unit of the agency (e.g., Regional Administrators of U.S. EPA). (40 C.F.R. § 122.22(a)(3).)
3. All reports required by this Order and other information requested by the Central Coast Water Board, State Water Board, or U.S. EPA shall be signed by a person described in Standard Provisions – Reporting V.B.2 above, or by a duly authorized representative of that person. A person is a duly authorized representative only if:
  - a. The authorization is made in writing by a person described in Standard Provisions – Reporting V.B.2 above (40 C.F.R. § 122.22(b)(1));

- b. The authorization specifies either an individual or a position having responsibility for the overall operation of the regulated facility or activity such as the position of plant manager, operator of a well or a well field, superintendent, position of equivalent responsibility, or an individual or position having overall responsibility for environmental matters for the company. (A duly authorized representative may thus be either a named individual or any individual occupying a named position.) (40 C.F.R. § 122.22(b)(2)); and
  - c. The written authorization is submitted to the Central Coast Water Board and State Water Board. (40 C.F.R. § 122.22(b)(3).)
4. If an authorization under Standard Provisions – Reporting V.B.3 above is no longer accurate because a different individual or position has responsibility for the overall operation of the facility, a new authorization satisfying the requirements of Standard Provisions – Reporting V.B.3 above must be submitted to the Central Coast Water Board and State Water Board prior to or together with any reports, information, or applications, to be signed by an authorized representative. (40 C.F.R. § 122.22(c).)
  5. Any person signing a document under Standard Provisions – Reporting V.B.2 or V.B.3 above shall make the following certification:

“I certify under penalty of law that this document and all attachments were prepared under my direction or supervision in accordance with a system designed to assure that qualified personnel properly gather and evaluate the information submitted. Based on my inquiry of the person or persons who manage the system or those persons directly responsible for gathering the information, the information submitted is, to the best of my knowledge and belief, true, accurate, and complete. I am aware that there are significant penalties for submitting false information, including the possibility of fine and imprisonment for knowing violations.” (40 C.F.R. § 122.22(d).)

### **C. Monitoring Reports**

1. Monitoring results shall be reported at the intervals specified in the Monitoring and Reporting Program (Attachment E) in this Order. (40 C.F.R. § 122.41(l)(4).)
2. Monitoring results must be reported on a Discharge Monitoring Report (DMR) form or forms provided or specified by the Central Coast Water Board, State Water Board, or EPA for reporting results of monitoring of sludge use or disposal practices. (40 C.F.R. § 122.41(l)(4)(i).)
3. If the Discharger monitors any pollutant more frequently than required by this Order using test procedures approved under 40 C.F.R. part 136, or another method required for an industry-specific waste stream under 40 C.F.R. subchapters N or O, the results of such monitoring shall be included in the calculation and reporting of the data submitted in the DMR or sludge reporting form specified by the Central Coast Water Board. (40 C.F.R. § 122.41(l)(4)(ii).)
4. Calculations for all limitations, which require averaging of measurements, shall utilize an arithmetic mean unless otherwise specified in this Order. (40 C.F.R. § 122.41(l)(4)(iii).)

#### **D. Compliance Schedules**

Reports of compliance or noncompliance with, or any progress reports on, interim and final requirements contained in any compliance schedule of this Order, shall be submitted no later than 14 days following each schedule date. (40 C.F.R. § 122.41(l)(5).)

#### **E. Twenty-Four Hour Reporting**

1. The Discharger shall report any noncompliance that may endanger health or the environment. Any information shall be provided orally within 24 hours from the time the Discharger becomes aware of the circumstances. A written submission shall also be provided within five (5) days of the time the Discharger becomes aware of the circumstances. The written submission shall contain a description of the noncompliance and its cause; the period of noncompliance, including exact dates and times, and if the noncompliance has not been corrected, the anticipated time it is expected to continue; and steps taken or planned to reduce, eliminate, and prevent reoccurrence of the noncompliance. (40 C.F.R. § 122.41(l)(6)(i).)
2. The following shall be included as information that must be reported within 24 hours under this paragraph (40 C.F.R. § 122.41(l)(6)(ii)):
  - a. Any unanticipated bypass that exceeds any effluent limitation in this Order. (40 C.F.R. § 122.41(l)(6)(ii)(A).)
  - d. Any upset that exceeds any effluent limitation in this Order. (40 C.F.R. § 122.41(l)(6)(ii)(B).)
3. The Central Coast Water Board may waive the above-required written report under this provision on a case-by-case basis if an oral report has been received within 24 hours. (40 C.F.R. § 122.41(l)(6)(iii).)

#### **F. Planned Changes**

The Discharger shall give notice to the Central Coast Water Board as soon as possible of any planned physical alterations or additions to the permitted facility. Notice is required under this provision only when (40 C.F.R. § 122.41(l)(1)):

1. The alteration or addition to a permitted facility may meet one of the criteria for determining whether a facility is a new source in section 122.29(b) (40 C.F.R. § 122.41(l)(1)(i)); or
2. The alteration or addition results in a significant change in the Discharger's sludge use or disposal practices, and such alteration, addition, or change may justify the application of permit conditions that are different from or absent in the existing permit, including notification of additional use or disposal sites not reported during the permit application process or not reported pursuant to an approved land application plan. (40 C.F.R. § 122.41(l)(1)(iii).)

#### **G. Anticipated Noncompliance**

The Discharger shall give advance notice to the Central Coast Water Board or State Water Board of any planned changes in the permitted facility or activity that may result in noncompliance with this Order's requirements. (40 C.F.R. § 122.41(l)(2).)

#### **H. Other Noncompliance**

The Discharger shall report all instances of noncompliance not reported under Standard Provisions – Reporting V.C, V.D, and V.E above at the time monitoring reports are submitted. The reports shall contain the information listed in Standard Provision – Reporting V.E above. (40 C.F.R. § 122.41(l)(7).)

#### **I. Other Information**

When the Discharger becomes aware that it failed to submit any relevant facts in a permit application, or submitted incorrect information in a permit application or in any report to the Central Coast Water Board, State Water Board, or U.S. EPA, the Discharger shall promptly submit such facts or information. (40 C.F.R. § 122.41(l)(8).)

### **VI. STANDARD PROVISIONS – ENFORCEMENT**

The Central Coast Water Board is authorized to enforce the terms of this permit under several provisions of the Water Code, including, but not limited to, sections 13385, 13386, and 13387.

### **VII. ADDITIONAL PROVISIONS – NOTIFICATION LEVELS**

#### **A. Publicly-Owned Treatment Works (POTWs)**

All POTWs shall provide adequate notice to the Central Coast Water Board of the following (40 C.F.R. § 122.42(b)):

1. Any new introduction of pollutants into the POTW from an indirect discharger that would be subject to sections 301 or 306 of the CWA if it were directly discharging those pollutants (40 C.F.R. § 122.42(b)(1)); and
2. Any substantial change in the volume or character of pollutants being introduced into that POTW by a source introducing pollutants into the POTW at the time of adoption of the Order. (40 C.F.R. § 122.42(b)(2).)
3. Adequate notice shall include information on the quality and quantity of effluent introduced into the POTW as well as any anticipated impact of the change on the quantity or quality of effluent to be discharged from the POTW. (40 C.F.R. § 122.42(b)(3).)

### **VIII. CENTRAL COAST WATER BOARD STANDARD PROVISIONS (REVISED 2013)**

#### **A. Central Coast Standard Provision – Prohibitions**

1. Introduction of “incompatible wastes” to the treatment system is prohibited.
2. Discharge of high-level radiological waste and of radiological, chemical, and biological warfare agents is prohibited.
3. Discharge of “toxic pollutants” in violation of effluent standards and prohibitions established under section 307(a) of the Clean Water Act (CWA) is prohibited.

4. Discharge of sludge, sludge digester or thickener supernatant, and sludge drying bed leachate to drainageways, surface waters, or the ocean is prohibited.
5. Introduction of pollutants into the collection, treatment, or disposal system by and “indirect discharger” that:
  - a. Inhibit or disrupt the treatment process, system operation, or the eventual use or disposal of sludge; or,
  - b. Flow through the system to the receiving water untreated; and,
  - c. Cause or “significantly contribute” to a violation of any requirement of this Order, is prohibited.
6. Introduction of “pollutant free” wastewater to the collection, treatment, and disposal system in amounts that threaten compliance with this order is prohibited.

**B. Central Coast Standard Provision – Provisions**

1. Collection, treatment, and discharge of waste shall not create a nuisance or pollution, as defined by California Water Code (CWC) 13050.
2. All facilities used for transport or treatment of wastes shall be adequately protected from inundation and washout as the result of a 100-year frequency flood.
3. Operation of collection, treatment, and disposal systems shall be in a manner that precludes public contact with wastewater.
4. Collected screenings, sludges, and other solids removed from liquid wastes shall be disposed in a manner approved by the Executive Officer.
5. Publicly owned wastewater treatment plans shall be supervised and operated by persons possessing certificates of appropriate grade pursuant to Title 23 of the California Administrative Code.
6. After notice and opportunity for a hearing, this order may be terminated for cause, including, but not limited to:
  - c. Violation of any term or condition contained in this order;
  - d. Obtaining this order by misrepresentation, or by failure to disclose fully all relevant facts;
  - e. A change in any condition or endangerment to human health or environment that requires a temporary or permanent reduction or elimination of the authorized discharge; and,
  - f. A substantial change in character, location, or volume of the discharge.
7. Provisions of this permit are severable. If any provision of the permit is found invalid, the remainder of the permit shall not be affected.
8. After notice and opportunity for hearing, this order may be modified or revoked and reissued for cause, including:

- a. Promulgation of a new or revised effluent standard or limitation;
  - b. A material change in character, location, or volume of the discharge;
  - c. Access to new information that affects the terms of the permit, including applicable schedules;
  - d. Correction of technical mistakes or mistaken interpretations of law; and,
  - e. Other causes set forth under Sub-part D of 40 CFR Part 122.
9. Safeguards shall be provided to ensure maximal compliance with all terms and conditions of this permit. Safeguards shall include preventative and contingency plans and may also include alternative power sources, stand-by generators, retention capacity, operative procedures, or other precautions. Preventative and contingency plans for controlling and minimizing the effect of accidental discharges shall:
  - a. Identify possible situations that could cause “upset,” “overflow,” or “bypass,” or other noncompliance. (Loading and storage areas, power outage, waste treatment unit outage, and failure of process equipment, tanks and pipes should be considered).
  - b. Evaluate the effectiveness of present facilities and procedures and describe procedures and steps to minimize or correct any adverse environmental impact resulting from noncompliance with the permit.
10. Physical Facilities shall be designed and constructed according to accepted engineering practice and shall be capable of full compliance with this order when properly operated and maintained. Proper operation and maintenance shall be described in an Operation and Maintenance Manual. Facilities shall be accessible during the wet-weather season.
11. The discharger shall at all times properly operate and maintain all facilities and systems of treatment and control (and related appurtenances) that are installed or used by the discharger to achieve compliance with the conditions of this order. Electrical and mechanical equipment shall be maintained in accordance with appropriate practices and standards, such as NFPA 70B, *Recommended Practice for Electrical Equipment Maintenance*; NFPA 70E, *Standard for Electrical Safety in the Workplace*; ANSI/NETA MTS *Standard for Maintenance: Testing Specifications for Electrical Power Equipment and Systems*, or procedures established by insurance companies or industry resources.
12. If the discharger’s facilities are equipped with SCADA or other systems that implement wireless, remote operation, the discharger should implement appropriate safeguards against unauthorized access to the wireless systems. Standards such as NIST SP 800-53, *Recommended Security Controls for Federal Information Systems*, can provide guidance.
13. Production and use of reclaimed water is subject to the approval of the Central Coast Board. Production and use of reclaimed water shall be in conformance with reclamation criteria established in Chapter 3, Title 22, of the California Administrative Code and Chapter 7, Division 7, of the CWC. An engineering report pursuant to section 60323, Title 22, of the California Administrative Code is required and a waiver or water reclamation requirements from the Central Coast Board is required before reclaimed water is supplied for any use, or to any user, not specifically identified and approved either in this Order or another order issued by this Board.

### **C. Central Coast Standard Provisions – General Monitoring Requirements**

1. If results of monitoring a pollutant appear to violate effluent limitations based on a weekly, monthly, 30-day, or six-month period, but compliance or non-compliance cannot be validated because sampling is too infrequent, the frequency of sampling shall be increased to validate the test within the next monitoring period. The increased frequency shall be maintained until the Executive Officer agrees the original monitoring frequency may be resumed.

For example, if copper is monitored annually and results exceed the six-month median numerical effluent limitation in the permit, monitoring of copper must be increased to a frequency of at least once every two months (Central Coast Standard Provisions – Definitions I.G.13.). If suspended solids are monitored weekly and results exceed the weekly average numerical limit in the permit, monitoring of suspended solids must be increased to at least four (4) samples every week (Central Coast Standard Provisions – Definitions I.G.14.).

2. Water quality analyses performed in order to monitor compliance with this permit shall be by a laboratory certified by the State Water Board for the constituent(s) being analyzed. Bioassay(s) performed in order to monitor compliance with this permit shall be in accord with guidelines approved by the State Water Board and the State Department of Fish and Wildlife. If the laboratory used or proposed for use by the discharger is not certified by the State Water Board or, where appropriate, the Department of Fish and Wildlife due to restrictions in the State's laboratory certification program, the discharger shall be considered in compliance with this provision provided:
  - a. Data results remain consistent with results of samples analyzed by the Central Coast Water Board;
  - b. A quality assurance program is used at the laboratory, including a manual containing steps followed in this program that is available for inspections by the staff of the Central Coast Water Board; and,
  - c. Certification is pursued in good faith and obtained as soon as possible after the program is reinstated.
3. Samples and measurements taken for the purpose of monitoring shall be representative of the monitored activity. Samples shall be taken during periods of peak loading conditions. Influent samples shall be samples collected from the combined flows of all incoming wastes, excluding recycled wastes. Effluent samples shall be samples collected downstream of the last treatment unit and tributary flow and upstream of any mixing with receiving waters.
4. All monitoring instruments and devices used by the discharger to fulfill the prescribed monitoring program shall be properly maintained and calibrated as necessary to ensure their continued accuracy.

### **D. Central Coast Standard Provisions – General Reporting Requirements**

1. Reports of marine monitoring surveys conducted to meet receiving water monitoring requirements of the Monitoring and Reporting Program shall include at least the following information:



- a. A description of climatic and receiving water characteristics at the time of sampling (weather observations, floating debris, discoloration, wind speed and direction, swell or wave action, time of sampling, tide height, etc.).
  - b. A description of sampling stations, including differences unique to each station (e.g., station location, grain size, rocks, shell litter, calcareous worm tubes, evident life, etc.).
  - c. A description of the sampling procedures and preservation sequence used in the survey.
  - d. A description of the exact method used for laboratory analysis. In general, analysis shall be conducted according to Central Coast Standard Provisions – C.1 above, and Federal Standard Provision – Monitoring III.B. However, variations in procedure are acceptable to accommodate the special requirements of sediment analysis. All such variations must be reported with the test results.
  - e. A brief discussion of the results of the survey. The discussion shall compare data from the control station with data from the outfall stations. All tabulations and computations shall be explained.
2. Reports of compliance or noncompliance with, or any progress reports on, interim and final requirements contained in any compliance schedule shall be submitted within 14 days following each scheduled date unless otherwise specified within the permit. If reporting noncompliance, the report shall include a description of the reason, a description and schedule of tasks necessary to achieve compliance, and an estimated date for achieving full compliance. A second report shall be submitted within 14 days of full compliance.
  3. The “Discharger” shall file a report of waste discharge or secure a waiver from the Executive Officer at least 180 days before making any material change or proposed change in the character, location, or plume of the discharge.
  4. Within 120 days after the discharger discovers, or is notified by the Central Coast Water Board, that monthly average daily flow will or may reach design capacity of waste treatment and/or disposal facilities within four (4) years, the discharger shall file a written report with the Central Coast Water Board. The report shall include:
    - a. the best estimate of when the monthly average daily dry weather flow rate will equal or exceed design capacity; and,
    - b. a schedule for studies, design, and other steps needed to provide additional capacity for waste treatment and/or disposal facilities before the waste flow rate equals the capacity of present units.

In addition to complying with Federal Standard Provision – Reporting V.B., the required technical report shall be prepared with public participation and reviewed, approved and jointly submitted by all planning and building departments having jurisdiction in the area served by the waste collection, treatment, or disposal facilities.

5. All “Dischargers” shall submit reports electronically to the:

State Water Board’s California Integrated Water Quality System (CIWQS) database:  
<http://ciwqs.waterboards.ca.gov/>

In addition, "Dischargers" with designated major discharges shall submit a copy of each document to:

USEPA, Region 9's Discharge Monitoring Report (NetDMR) database:  
<https://netdmr.epa.gov/netdmr/public/login.htm>

Other correspondence may be sent to the Central Coast Region at:  
[centralcoast@waterboards.ca.gov](mailto:centralcoast@waterboards.ca.gov)

- 6.** Transfer of control or ownership of a waste discharge facility must be preceded by a notice to the Central Coast Water Board at least 30 days in advance of the proposed transfer date. The notice must include a written agreement between the existing "Discharger" and proposed "Discharger" containing specific date for transfer of responsibility, coverage, and liability between them. Whether a permit may be transferred without modification or revocation and reissuance is at the discretion of the Board. If permit modification or revocation and reissuance is necessary, transfer may be delayed 180 days after the Central Coast Water Board's receipt of a complete permit application. Please also see Federal Standard Provision – Permit Action II.C.
- 7.** Except for data determined to be confidential under CWA §308 (excludes effluent data and permit applications), all reports prepared in accordance with this permit shall be available for public inspection at the office of the Central Coast Water Board or Regional Administrator of USEPA. Please also see Federal Standard Provision – Records IV.C.
- 8.** By January 30 of each year, the discharger shall submit an annual report to the Central Coast Water Board. The report shall contain the following:
  - a.** Both tabular and graphical summaries of the monitoring data obtained during the previous year.
  - b.** A discussion of the previous year's compliance record and corrective actions taken, or which may be needed, to bring the discharger into full compliance.
  - c.** An evaluation of wastewater flows with projected flow rate increases over time and the estimated date when flows will reach facility capacity.
  - d.** A discussion of operator certification and a list of current operating personnel and their grades of certification.
  - e.** The date of the facility's Operation and Maintenance Manual (including contingency plans as described in Provision B.9), the date the manual was last reviewed, and whether the manual is complete and valid for the current facility.
  - f.** A discussion of the laboratories used by the discharger to monitor compliance with effluent limits and a summary of performance relative to Section C, General Monitoring Requirements.
  - g.** If the facility treats industrial or domestic wastewater and there is no provision for periodic sludge monitoring in the Monitoring and Reporting Program, the report shall include a summary of sludge quantities, analyses of its chemical and moisture content, and its ultimate destination.
  - h.** If appropriate, the report shall also evaluate the effectiveness of the local source control or pretreatment program using the State Water Resources Control Board's "Guidelines for Determining the Effectiveness of Local Pretreatment Program."

**E. Central Coast Standard Provisions – General Pretreatment Provisions**

1. Discharge of pollutants by "indirect dischargers" in specific industrial sub-categories (appendix C, 40 CFR Part 403), where categorical pretreatment standards have been established, or are to be established, (according to 40 CFR Chapter 1, Subchapter N), shall comply with the appropriate pretreatment standards:
  - a. By the date specified therein;
  - b. Within three (3) years of the effective date specified therein, but in no case later than July 1, 1984; or,
  - c. If a new indirect discharger, upon commencement of discharge

**F. Central Coast Standard Provision – Enforcement**

1. Any person failing to file a report of waste discharge or other report as required by this permit shall be subject to a civil penalty not to exceed \$5,000 per day.
2. Upon reduction, loss, or failure of the treatment facility, the "Discharger" shall, to the extent necessary to maintain compliance with this permit, control production or all discharges, or both, until the facility is restored or an alternative method of treatment is provided.

**G. Central Coast Standard Provisions – Definitions (Not otherwise included in Attachment A to this Order)**

1. A "composite sample" is a combination of no fewer than eight (8) individual samples obtained at equal time intervals (usually hourly) over the specified sampling (composite) period. The volume of each individual sample is proportional to the flow rate at the time of sampling. The period shall be specified in the Monitoring and Reporting Program ordered by the Executive Officer.
2. "Daily Maximum" limit means the maximum acceptable concentration or mass emission rate of a pollutant measured during a calendar day or during any 24-hour period reasonably representative of the calendar day for purposes of sampling. It is normally compared with results based on "composite samples" except for ammonia, total chlorine, phenolic compounds, and toxicity concentration. For all exceptions, comparisons will be made with results from a "grab sample".
3. "Discharger", as used herein, means, as appropriate: (1) the Discharger, (2) the local sewerage entity (when the collection system is not owned and operated by the Discharger), or (3) "indirect discharger" (where "Discharger" appears in the same paragraph as "indirect discharger", it refers to the discharger.)
4. "Duly Authorized Representative" is one where:
  - a. the authorization is made in writing by a person described in the signatory paragraph of Federal Standard Provision V.B.;
  - b. the authorization specifies either an individual or the occupant of a position having either responsibility for the overall operation of the regulated facility, such as the plant manager, or overall responsibility for environmental matters of the company; and,

- c. the written authorization was submitted to the Central Coast Water Board.
- 5. A "grab sample" is defined as any individual sample collected in less than 15 minutes. "Grab samples" shall be collected during peak loading conditions, which may or may not be during hydraulic peaks. It is used primarily in determining compliance with the daily maximum limits identified in Central Coast Standard Provision – Provision G.2. and instantaneous maximum limits.
- 6. "Hazardous substance" means any substance designated under 40 CFR Part 116 pursuant to Section 311 of the Clean Water Act.
- 7. "Incompatible wastes" are:
  - a. Wastes which create a fire or explosion hazard in the treatment works;
  - b. Wastes which will cause corrosive structural damage to treatment works, but in no case wastes with a pH lower than 5.0 unless the works is specifically designed to accommodate such wastes;
  - c. Solid or viscous wastes in amounts which cause obstruction to flow in sewers, or which cause other interference with proper operation of treatment works;
  - d. Any waste, including oxygen demanding pollutants (BOD, etc), released in such volume or strength as to cause inhibition or disruption in the treatment works and subsequent treatment process upset and loss of treatment efficiency; and,
  - e. Heat in amounts that inhibit or disrupt biological activity in the treatment works or that raise influent temperatures above 40°C (104°F) unless the treatment works is designed to accommodate such heat.
- 8. "Indirect Discharger" means a non-domestic discharger introducing pollutants into a publicly owned treatment and disposal system.
- 9. "Log Mean" is the geometric mean. Used for determining compliance of fecal or total coliform populations, it is calculated with the following equation:

$$\text{Log Mean} = (C_1 \times C_2 \times \dots \times C_n)^{1/n},$$

in which "n" is the number of days samples were analyzed during the period and any "C" is the concentration of bacteria (MPN/100 ml) found on each day of sampling. "n" should be five or more.

- 10. "Mass emission rate" is a daily rate defined by the following equations:

mass emission rate (lbs/day) = 8.34 x Q x C; and,

mass emission rate (kg/day) = 3.79 x Q x C,

where "C" (in mg/L) is the measured daily constituent concentration or the average of measured daily constituent concentrations and "Q" (in MGD) is the measured daily flowrate or the average of measured daily flow rates over the period of interest.

- 11. The "Maximum Allowable Mass Emission Rate," whether for a month, week, day, or six-month period, is a daily rate determined with the formulas in paragraph G.10, above,

using the effluent concentration limit specified in the permit for the period and the average of measured daily flows (up to the allowable flow) over the period.

12. "Maximum Allowable Six-Month Median Mass Emission Rate" is a daily rate determined with the formulas in Central Coast Standard Provision – Provision G.10, above, using the "six-month Median" effluent limit specified in the permit, and the average of measured daily flows (up to the allowable flow) over a 180-day period.
13. "Median" is the value below which half the samples (ranked progressively by increasing value) fall. It may be considered the middle value, or the average of two middle values.
14. "Monthly Average" (or "Weekly Average", as the case may be) is the arithmetic mean of daily concentrations or of daily mass emission rates over the specified 30-day (or 7-day) period.

$$\text{Average} = (X_1 + X_2 + \dots + X_n) / n$$

in which "n" is the number of days samples were analyzed during the period and "X" is either the constituent concentration (mg/l) or mass emission rate (kg/day or lbs/day) for each sampled day. "n" should be four or greater.

15. "Municipality" means a city, town, borough, county, district, association, or other public body created by or under State law and having jurisdiction over disposal of sewage, industrial waste, or other waste.
16. "Overflow" means the intentional or unintentional diversion of flow from the collection and transport systems, including pumping facilities.
17. "Pollutant-free wastewater" means inflow and infiltration, stormwaters, and cooling waters and condensates which are essentially free of pollutants.
18. "Primary Industry Category" means any industry category listed in 40 CFR Part 122, Appendix A.
19. "Removal Efficiency" is the ratio of pollutants removed by the treatment unit to pollutants entering the treatment unit. Removal efficiencies of a treatment plant shall be determined using "Monthly averages" of pollutant concentrations (C, in mg/l) of influent and effluent samples collected about the same time and the following equation (or its equivalent):  
$$C_{\text{Effluent}} \text{ Removal Efficiency (\%)} = 100 \times (1 - C_{\text{Effluent}} / C_{\text{Influent}})$$
20. "Severe property damage" means substantial physical damage to property, damage to treatment facilities which causes them to become inoperable, or substantial and permanent loss to natural resources which can reasonably be expected to occur in the absence of a "bypass". It does not mean economic loss caused by delays in production.
21. "Sludge" means the solids, residues, and precipitates separated from, or created in, wastewater by the unit processes of a treatment system.
22. To "significantly contribute" to a permit violation means an "indirect discharger" must:

- a. Discharge a daily pollutant loading in excess of that allowed by contract with the "Discharger" or by Federal, State, or Local law;
  - b. Discharge wastewater which substantially differs in nature or constituents from its average discharge;
  - c. Discharge pollutants, either alone or in conjunction with discharges from other sources, which results in a permit violation or prevents sewage sludge use or disposal; or
  - d. Discharge pollutants, either alone or in conjunction with pollutants from other sources that increase the magnitude or duration of permit violations.
23. "Toxic Pollutant" means any pollutant listed as toxic under Section 307 (a) (1) of the Clean Water Act or under 40 CFR Part 122, Appendix D. Violation of maximum daily discharge limitations are subject to 24-hour reporting (Federal Standard Provisions V.E.).
24. "Zone of Initial Dilution" means the region surrounding or adjacent to the end of an outfall pipe or diffuser ports whose boundaries are defined through calculation of a plume model verified by the State Water Board

## ATTACHMENT E – MONITORING AND REPORTING PROGRAM

### Contents

I.	General Monitoring Provisions .....	E-2
II.	Monitoring Locations.....	E-3
III.	Influent Monitoring Requirements.....	E-4
IV.	Effluent Monitoring Requirements .....	E-5
	A. Monitoring Location EFF-001.....	E-5
V.	Whole Effluent Toxicity Testing Requirements.....	E-7
VI.	Land Discharge Monitoring Requirements – Not Applicable.....	E-10
VII.	Recycling Monitoring Requirements.....	E-10
VIII.	Receiving water monitoring requirements.....	E-10
IX.	Benthic monitoring.....	E-11
X.	Data Analysis .....	E-15
XI.	Biosolids Monitoring.....	E-16
XII.	Other Monitoring Requirements .....	E-20
XIII.	Reporting Requirements.....	E-23
	A. General Monitoring and Reporting Requirements.....	E-23
	B. Self-Monitoring Reports (SMR’s) .....	E-24
	C. Discharge Monitoring Reports (DMR’s).....	E-26
	D. Other Reports .....	E-26

### Tables

Table E-1.	Monitoring Station Locations .....	E-4
Table E-2.	Influent Monitoring.....	E-4
Table E-3.	Effluent Monitoring – Discharge Point 001 .....	E-5
Table E-4.	Remaining Priority Toxic Pollutants <sup>[1]</sup> .....	E-6
Table E-5.	Approved Tests – Chronic Toxicity .....	E-8
Table E-6.	Surf Zone Monitoring.....	E-10
Table E-7.	Near Shore Monitoring.....	<b>Error! Bookmark not defined.</b>
Table E-8.	Benthic Sediment Monitoring.....	E-12
Table E-9.	Biosolids Monitoring Requirements.....	E-17
Table E-10.	Reclaimed Water Influent Monitoring .....	E-20
Table E-11.	Reclaimed Water Effluent Monitoring – Discharge Point 002.....	E-20
Table E-12.	Monitoring Periods and Reporting Schedule .....	E-24

## ATTACHMENT E – MONITORING AND REPORTING PROGRAM (MRP)

The Code of Federal Regulations (40 C.F.R. § 122.48) requires that all NPDES permits specify monitoring and reporting requirements. Water Code sections 13267 and 13383 also authorize the Regional Water Quality Control Board (Central Coast Water Board) to require technical and monitoring reports. This MRP establishes monitoring and reporting requirements that implement federal and California regulations.

The monitoring program for a discharger receiving a Clean Water Act Section 301 (h) Modified National Pollutant Discharge Elimination System (NPDES) permit is intended to: a) document short and long-term effects of the discharge on receiving waters, sediments, biota, and on beneficial uses of the receiving water; b) determine compliance with NPDES permit requirements and conditions; and c) assess the effectiveness of industrial pretreatment and toxics control programs. Because this discharger has upgraded to full secondary treatment process, excess monitoring requirements have been removed.

### I. GENERAL MONITORING PROVISIONS

#### A. Laboratory Certification

Laboratories analyzing monitoring samples shall be certified by the State Water Resources Control Board's (State Water Board) Division of Drinking Water (DDW), in accordance with the provision of Water Code section 13176, and must include quality assurance/quality control data with their reports.

**B.** Samples and measurements taken as required herein shall be representative of the volume and nature of the monitored discharge. All samples shall be taken at the monitoring locations specified below and, unless otherwise specified, before the monitored flow joins or is diluted by any other waste stream, body of water, or substance. Monitoring locations shall now be changed without notification to and approval of the Central Coast Water Board.

**C.** Appropriate flow measurement devices and methods consistent with accepted scientific practices shall be selected and used to ensure the accuracy and reliability of measurements of the volume of monitored discharges. The devices shall be installed, calibrated, and maintained to ensure that the accuracy of the measurements is consistent with the accepted capability of that type of device. Devices selected shall be capable of measuring flows with a maximum deviation of less than  $\pm 10$  percent from true discharge rates throughout the range of expected discharge volumes. Guidance in selection, installation, calibration, and operation of acceptable flow measurement devices can be obtained from the following references.

1. *A Guide to Methods and Standards for the Measurement of Water Flow*, U.S. Department of Commerce, National Bureau of Standards, NBS Special Publication 421, May 1975, 96 pp. (Available from the U.S. Government Printing Office, Washington, D.C. 20402. Order by SD Catalog No. C13.10:421.)
2. *Water Measurement Manual*, U.S. Department of Interior, Bureau of Reclamation, Second Edition, Revised Reprint, 1974, 327 pp. (Available from the U.S. Government Printing Office, Washington D.C. 20402. Order by Catalog No. 172.19/2:W29/2, Stock No. S/N 24003-0027.)



3. *Flow Measurement in Open Channels and Closed Conduits*, U.S. Department of Commerce, National Bureau of Standards, NBS Special Publication 484, October 1977, 982 pp. (Available in paper copy or microfiche from National Technical Information Services (NTIS) Springfield, VA 22050. Order by NTIS No. PB-273 535/5ST.)
  4. *NPDES Compliance Sampling Manual*, U.S. Environmental Protection Agency, Office of Water Enforcement, Publication MCD-51, 1977, 140 pp. (Available from the General Services Administration (8FFS), Centralized Mailing Lists Services, Building 41, Denver Federal Center, CO 80225.)
- D.** All monitoring instruments and devices used by the Discharger to fulfill the prescribed monitoring program shall be properly maintained and calibrated as necessary to ensure their continued accuracy. All flow measurement devices shall be calibrated at least once per year to ensure continued accuracy of the devices.
- E.** Monitoring results, including noncompliance, shall be reported at intervals and in a manner specified in this MRP.
- F.** Unless otherwise specified by this MRP, all monitoring shall be conducted according to test procedures established at 40 C.F.R. 136, Guidelines Establishing Test Procedures for Analysis of Pollutants. All analyses shall be conducted using the lowest practical quantitation limit achievable using the specified methodology. Where effluent limitations are set below the lowest achievable quantitation limits, pollutants not detected at the lowest practical quantitation limits will be considered in compliance with effluent limitations. Analysis for toxic pollutants specified in Table 1 of the California Ocean Plan shall be conducted in accordance with procedures described in the California Ocean Plan and restated in this MRP.
- G.** Monitoring and sampling periods are defined as follows unless otherwise specified in this MRP:
- Daily:** Midnight through 11:59 PM, or any 24-hour period that reasonably represents a calendar day for purposes of sampling.
- Weekly:** Sunday through Saturday (Note: For weekly monitoring and sampling periods that start in one monthly reporting period but end in the next, the Discharger may report the weekly data in the monthly monitoring report containing the last day of the weekly period.)
- Monthly:** 1<sup>st</sup> day of calendar month through last day of calendar month.
- Annually:** January 1<sup>st</sup> through December 31<sup>st</sup>

## II. MONITORING LOCATIONS

The Discharger shall establish the following monitoring locations to demonstrate compliance with the effluent limitations, discharge specifications, and other requirements in this Order:

**Table E-1. Monitoring Station Locations**

Monitoring Location Name	Distance from Diffuser Center (m)	Monitoring Location Description
INF-001	---	Influent wastewater prior to treatment, where representative samples of raw wastewater can be obtained (formerly M-INF).
EFF-001	---	Location where representative sample of effluent, to be discharged through the ocean outfall, can be collected, after final treatment and disinfection steps and before contact with receiving water. Latitude: 34° 24' 19" N Longitude: 119° 49' 56" W
<b>Surf Zone Monitoring Locations</b>		
A	---	Goleta Point.
A1	---	500 meters downcoast of Goleta Point.
A2	---	1,000 meters west of outfall.
B	---	300 meters west of outfall.
C	---	Onshore at outfall.
D	---	300 meters east of outfall.
E	---	1,000 meters east of outfall.
<b>Benthic Monitoring Locations</b>		
B-1	1,500	1,500 meters west and at same depth as diffuser. Latitude: 34° 24' 17" N Longitude: 119° 50' 31" W
B-2	500	500 meters west and at same depth as diffuser. Latitude: 34° 24' 25" N Longitude: 119° 49' 72" W
B-3	250	250 meters west and at same depth as diffuser. Latitude: 34° 24' 27" N Longitude: 119° 49' 55" W
B-4	25	25 meters west and at same depth as diffuser. Latitude: 34° 24' 36" N Longitude: 119° 49' 36" W
B-5	25	25 meters east and at same depth as diffuser. Latitude: 34° 24' 40" N Longitude: 119° 49' 29" W
B-6	3,000	3,000 meters east and at same depth as diffuser. Latitude: 34° 24' 45" N Longitude: 119° 47' 54" W
<b>Plume Monitoring Stations</b>		
WC-ZID		25 meters from the outfall in the wastewater plume
WC-100M		In the plume, 100 meters from the outfall on the same heading as WC-ZID.

The north latitude and west longitude information in Table E-1 are approximate for administrative purposes.

**III. INFLUENT MONITORING REQUIREMENTS**

**A. Monitoring Location INF-001**

1. The Discharger shall monitor representative samples<sup>1</sup> of influent to the Facility at Monitoring Location INF-001 as follows:

**Table E-2. Influent Monitoring**

Parameter	Units	Sample Type	Minimum Sampling Frequency
-----------	-------	-------------	----------------------------

<sup>1</sup> Influent samples shall be corrected to compensate for in-plant return flows.

Daily Flow	MGD	Metered	1/Day
Maximum Daily Flow	MGD	Metered	1/Day
Mean Daily Flow	MGD	Calculated	1/Month
Biochemical Oxygen Demand 5-day @ 20°C (BOD <sub>5</sub> )	mg/L	C-24 <sup>[1]</sup>	1/Month
Total Suspended Solids (TSS)	mg/L	C-24 <sup>[1]</sup>	1/Month
pH	s.u.	Grab	1/Week
Ocean Plan Table 1 Constituents <sup>[2]</sup>	µg/L	C-24 <sup>[1]</sup>	October 2018
Remaining Priority Toxic Pollutants <sup>[3]</sup>	µg/L	C-24 <sup>[1]</sup>	October 2018

Units:

- MGD = million gallons per day
- µg/L = micrograms per liter
- mg/L = milligrams per liter
- C-24 = 24 hour composite
- s.u. = standard units

- <sup>[1]</sup> Composite samples may be taken by a proportional sampling devise approved by the Executive Officer or by grab samples composited in proportion to flow. In compositing grab samples, the sampling interval shall not exceed one hour.
- <sup>[2]</sup> Those pollutants identified in Table 1 of the Ocean Plan (2015) other than the metals listed above in this table. Analyses, compliance determination, and reporting for these pollutants shall adhere to applicable provisions of the Ocean Plan, including the Standard Monitoring Procedures presented in Appendix III of the Ocean Plan. The Discharger shall establish calibration standards (or require that their contract laboratory do so) so that the Minimum Levels (MLs) presented in Appendix II of the Ocean Plan are the lowest calibration standards. The Discharger and its analytical laboratory shall select MLs, which are below applicable water quality criteria of Table 1; and when applicable water quality criteria are below all MLs, the Discharger and its analytical laboratory shall select the lowest ML.
- <sup>[3]</sup> See Table E-4 for Remaining Priority Toxic Pollutants.

**IV. EFFLUENT MONITORING REQUIREMENTS**

**A. Monitoring Location EFF-001**

1. The Discharger shall monitor effluent at Monitoring Location EFF-001. If more than one analytical test method is listed for a given parameter, the Discharger must select from the listed methods and corresponding Minimum Level:

**Table E-3. Effluent Monitoring**

Parameter	Units	Sample Type	Minimum Sampling Frequency
Daily Flow	MGD	Metered	1/Day
Maximum Daily Flow	MGD	Metered	1/Day
Mean Daily Flow	MGD	Calculated	1/Month
Temperature	°C	Grab	5/Week
Total Coliform Bacteria <sup>[1][2]</sup>	MPN/100mL	Grab	5/Week
Fecal Coliform Bacteria <sup>[1]</sup>	MPN/100mL	Grab	5/Week
Enterococcus <sup>[1]</sup>	MPN/100mL	Grab	5/Week
BOD <sub>5</sub>	mg/L	C-24	5/Week
TSS	mg/L	C-24	5/Week
Settleable Solids	mL/L	Grab	5/Week
Chronic Toxicity <sup>[4]</sup>	TUc	C-24	1/Quarter <sup>[5]</sup>

Parameter	Units	Sample Type	Minimum Sampling Frequency
Oil and Grease	mg/L	Grab	1/Week
pH	s.u.	Grab	5/Week
Turbidity	NTUs	Grab	5/Week
Total Chlorine Residual (chlorine contact tank)	mg/L	Grab	1/Day
Total Chlorine Residual (Final Effluent)	mg/L	Continuous	Continuous
Ocean Plan Table 1 Pollutants <sup>[6]</sup>	µg/L	C-24	1/Year (October)
Remaining Priority Toxic Pollutants <sup>[7]</sup>	µg/L	C-24	1/Year (October)

<sup>[1]</sup> The density of total coliform organisms shall also be monitored during chlorine contact tank maintenance procedures. The Discharger shall implement the Notification and Monitoring Procedures in the Event of Disinfection Failure, as specified in Monitoring and Reporting Section VIII.D.

If the density of total coliform organisms exceeds any of the limits specified in Item IV.A.2., above, for three consecutive months, the Discharger shall submit a technical engineering report, in addition to monthly monitoring reports, for the approval of the Executive Officer. The report shall include, but not be limited to, measures to identify sources of the exceedances, if not already identified, and measures to correct the deficiencies. The Discharger shall submit the report within 30 days of the end of the third month of violating the limitation. In addition, the Discharger shall monitor the surf-zone stations daily for one week following the last day on which violation of the effluent limitation occurred.

If a single sample exceeds any of the single sample maximum (SSM) standards, repeat sampling at that location shall be conducted to determine the extent and persistence of the exceedance. Repeat sampling shall be conducted within 24 hours of receiving analytical results and continued until the sample result is less than the SSM standard or until a sanitary survey is conducted to determine the source of the high bacterial densities.

<sup>[2]</sup> Detection methods used for total coliform bacteria shall be those presented in Table 1A of 40 CFR PART 136 (revised edition of May 14, 1999), unless alternate methods have been approved in advance by US EPA pursuant to 40 CFR PART 136.

<sup>[3]</sup> Acute bioassay tests shall be performed in accordance with MRP section V.A.

<sup>[4]</sup> Chronic bioassay tests shall be performed in accordance with MRP section V.B.

<sup>[5]</sup> Monitoring shall occur once per quarter during the months of January, April, July, and October.

<sup>[6]</sup> Those pollutants identified in Table 1 of the Ocean Plan (2015). Analyses, compliance determination, and reporting for these pollutants shall adhere to applicable provisions of the Ocean Plan, including the Standard Monitoring Procedures presented in Appendix III of the Ocean Plan. The Discharger shall instruct its analytical laboratory to establish calibration standards so that the Minimum Levels (MLs) presented in Appendix II of the Ocean Plan are the lowest calibration standards. The Discharger and its analytical laboratory shall select MLs, which are below applicable water quality criteria of Table 1; and when applicable water quality criteria are below all MLs, the Discharger and its analytical laboratory shall select the lowest ML. Metals shall be reported as total recoverable.

<sup>[7]</sup> See Table E-4 for Remaining Priority Toxic Pollutants.

**Table E-4. Remaining Priority Toxic Pollutants<sup>[1]</sup>**

Parameter	Units	Sample Type	Minimum Sampling Frequency
Acenaphthene	µg/L	24-hr Composite	1/Year (October)
1,2,4-Trichlorobenzene	µg/L	24-hr Composite	1/Year (October)
2-Chloronaphthalene	µg/L	24-hr Composite	1/Year (October)
2,6-Dinitrotoluene	µg/L	24-hr Composite	1/Year (October)
4-Chlorophenyl Phenyl Ether	µg/L	24-hr Composite	1/Year (October)
4-Bromophenyl Phenyl Ether	µg/L	24-hr Composite	1/Year (October)
Naphthalene	µg/L	24-hr Composite	1/Year (October)
Butylbenzyl Phthalate	µg/L	24-hr Composite	1/Year (October)
Di-n-Octyl Phthalate	µg/L	24-hr Composite	1/Year (October)

Parameter	Units	Sample Type	Minimum Sampling Frequency
Benzo(a)Anthracene	µg/L	24-hr Composite	1/Year (October)
Benzo(ghi) Perylene	µg/L	24-hr Composite	1/Year (October)
P-Chloro-M-Cresol	µg/L	24-hr Composite	1/Year (October)
2-Chlorophenol	µg/L	24-hr Composite	1/Year (October)
2,4-Dichlorophenol	µg/L	24-hr Composite	1/Year (October)
2,4-Dimethylphenol	µg/L	24-hr Composite	1/Year (October)
4,6-Dinitro-O-Cresol	µg/L	24-hr Composite	1/Year (October)
2-Nitrophenol	µg/L	24-hr Composite	1/Year (October)
4-Nitrophenol	µg/L	24-hr Composite	1/Year (October)
Pentachlorophenol	µg/L	24-hr Composite	1/Year (October)
Phenol	µg/L	24-hr Composite	1/Year (October)
1,1-Dichloroethane	µg/L	24-hr Composite	1/Year (October)
Chloroethane	µg/L	24-hr Composite	1/Year (October)
Endrin Aldehyde	µg/L	24-hr Composite	1/Year (October)
Trans-1,2-Dichloroethylene	µg/L	24-hr Composite	1/Year (October)
1,2-Dichloropropane	µg/L	24-hr Composite	1/Year (October)
1,3-Dichloropropylene	µg/L	24-hr Composite	1/Year (October)
Methylene Chloride	µg/L	24-hr Composite	1/Year (October)
2-Chloroethyl Vinyl Ether	µg/L	24-hr Composite	1/Year (October)

Units:

µg/L = micrograms per liter

C-24 = 24 hour composite

[1] From 40 CFR 131.36 (7-1-03 Editions) and EPA Application Form 3510-2A (Rev 1-99).

**V. WHOLE EFFLUENT TOXICITY TESTING REQUIREMENTS**

**A. Whole Effluent Chronic Toxicity – Monitoring Location EFF-001**

The presence of chronic toxicity shall be estimated as specified in *Short Term Methods for Estimating the Chronic Toxicity of Effluents and Receiving Waters to West Coast Marine and Estuarine Organisms*, EPA-821/600/R-95/136; *Short Term Methods for Estimating the Chronic Toxicity of Effluents and Receiving Waters to Marine and Estuarine Organisms*, EPA-600-4-01-003; *Procedures Manual for Conducting Toxicity Tests developed by the Marine Bioassay Project*, SWRCB 1996, 96-1WQ; and/or *Short Term Methods for Estimating the Chronic Toxicity of Effluents and Receiving Waters to Marine and Estuarine Organisms*, EPA/600/4-87-028 or subsequent editions.

Chronic toxicity measures a sublethal effect (e.g., reduced growth or reproduction) to experimental test organisms exposed to an effluent compared to that of the control organisms.

$$\text{Chronic Toxicity (TUc)} = 100/\text{NOEL}$$

The no observed effect level (NOEL) is the maximum tested concentration in a medium which does not cause known adverse effects upon chronic exposure in the species in question (i.e., the highest effluent concentration to which organisms are exposed in a chronic test that causes no observable adverse effects on the test organism; e.g., the highest concentration of a toxicant to which the values for the observed responses are not statistically significantly

different from the controls). Examples of chronic toxicity include, but are not limited to, measurements of toxicant effects on reproduction, growth, and sublethal effects that can include behavioral, physiological, and biochemical effects.

In accordance with the 2015 Ocean Plan, Appendix III, *Standard Monitoring Procedures*, the Discharger shall use the critical life stage toxicity tests specified in the table below to measure TUc. Other species or protocols will be added to the list after the State Water Board review and approval.

**Table E-5. Approved Tests – Chronic Toxicity**

Species	Effect	Tier <sup>[1]</sup>	Reference <sup>[2]</sup>
Giant Kelp, <i>Macrocystis pyrifera</i>	Percent germination; germ tube length	1	a, c
Red abalone, <i>Haliotis rufesens</i>	Abnormal shell development	1	a, c
Oyster, <i>Crassostrea gigas</i> ; Mussels, <i>Mytilus spp.</i>	Abnormal shell development; percent survival	1	a, c
Urchin, <i>Strongylocentrotus purpuratus</i> ; Sand dollar, <i>Dendraster excentricus</i>	Percent normal development; percent fertilization	1	a, c
Shrimp, <i>Holmesimysis costata</i>	Percent survival; growth	1	a, c
Shrimp, <i>Mysidopsis bahia</i>	Percent survival; fecundity	2	b, d
Topsmelt, <i>Atherinops affinis</i>	Larval growth rate; percent survival	1	a, c
Silversides, <i>Menidia beryllina</i>	Larval growth rate; percent survival	2	b, d

[1] First tier methods are preferred for compliance monitoring. If first tier organisms are not available, the Discharger can use a second tier test method following approval by the Regional Water Board.

[2] Protocol References:

- a. Chapman, G.A., D.L. Denton, and J.M. Lazochak. 1995. Short-term methods for estimating the chronic toxicity of effluents and receiving waters to west coast marine and estuarine organisms. U.S. EPA Report No. EPA/600/R-95/136.
- b. Klemm, D.J., G.E. Morrison, T.J. Norberg-King, W.J. Pelier, and M.A. Heber. 1994. Short-term methods for estimating the chronic toxicity of effluents and receiving waters to marine and estuarine organisms. U.S. EPA Report No. EPA-600-4-91-003.
- c. SWRCB 1996. Procedures Manual for Conducting Toxicity Tests Developed by the Marin Bioassay Project. 96-1WQ.
- d. Weber, C.I., W.B. Horning, I.I., D.J. Klemm, T.W. Neihsel, P.A. Lewis, E.L. Robinson, J. Menkedick and F. Kessler (eds). 1988. Short-term Methods for Estimating the Chronic Toxicity of Effluents and Receiving Waters to Marine and Estuarine Organisms. EPA/600/4-87/028. National Information Service, Springfield, VA.

Dilution and control waters shall be obtained from an area of the receiving waters, typically upstream, which is unaffected by the discharge. Standard dilution water can be used, if the receiving water itself exhibits toxicity or if approved by the Central Coast Water Board. If the dilution water used in testing is different from the water in which the test organisms were cultured, a second control sample using culture water shall be tested.

If the effluent to be discharged to a marine or estuarine system (e.g., salinity values in excess of 1,000 mg/L) originates from a freshwater supply, salinity of the effluent must be increased with dry ocean salts (e.g., FORTY FATHOMS®) to match salinity of the receiving water. This modified effluent shall then be tested using marine species.

**B. Conducting Toxicity Identification Evaluations (TIE) and Toxicity Reduction Evaluations (TRE)**

1. A TRE shall be implemented by the Discharger as specified by the Executive Officer. A TIE may be required as part of the TRE.
2. The TIE shall be conducted to identify and evaluate toxicity in accordance with procedures recommended by the United States Environmental Protection Agency (USEPA) which include the following:
  - a. Toxicity Identification Evaluation: Characterization of Chronically Toxic Effluents, Phase I, (USEPA, 1992a);
  - e. Methods for Aquatic Toxicity Identification Evaluations: Phase 1 Toxicity Characterization Procedures, Second Edition (USEPA, 1991a);
  - f. Methods for Aquatic Toxicity Identification Evaluations: Phase II Toxicity Identification Procedures for Sampling Exhibiting Acute and Chronic Toxicity (USEPA, 1993a); and
  - g. Methods for Aquatic Toxicity Identification Evaluations: Phase III Toxicity Confirmation Procedures for Samples Exhibiting Acute and Chronic Toxicity (USEPA, 1993b).
3. As part of the TIE investigation, the Discharger shall be required to implement its TRE work plan. The Discharger shall take all reasonable steps to control toxicity once the source of the toxicity is identified. A failure to conduct required toxicity tests or a TRE within a designated period may result in the establishment of numerical effluent limitations for chronic toxicity in a permit or appropriate enforcement action. Recommended guidance in conducting a TRE includes the following:
  - a. Toxicity Reduction Evaluation Guidance for Municipal Wastewater Treatment Plants, August 1999, EPA/833B-99/002; and
  - b. Clarifications Regarding Toxicity Reduction and Identification Evaluations in the National Pollutant Discharge Elimination System Program dated May 27, 2001, USEPA Office of Wastewater Management, Office of Regulatory Enforcement.

**C. Toxicity Reporting**

1. The Discharger shall include a full report of toxicity test results with the regular monthly monitoring report and include the following information.
  - a. Toxicity test results,
  - b. Dates of sample collection and initiation of each toxicity test, and
  - c. And/or toxicity discharge limitations (or value).
2. Toxicity test results shall be reported according to the appropriate guidance – *Methods for Measuring the Acute Toxicity of Effluents and Receiving Waters to Freshwater and Marine Organisms*, Fifth Edition, USEPA Office of Water, EPA-821-R-01-012 (2002) or the latest edition, or *Short Term Methods for Estimating the Chronic Toxicity of Effluents and Receiving Waters to Freshwater and Marine Organisms*, EPA-821-R-02-012 (2002) or subsequent editions.

3. If the initial investigation TRE workplan is used to determine that additional (accelerated) toxicity testing is unnecessary, these results shall be submitted with the monitoring report for the month in which investigation conducted under the TRE workplan occurred.
4. Within 14 days of receipt of test results exceeding a chronic toxicity discharge limitation, the Discharger shall provide written notification to the Executive Officer of:
  - a. Findings of TRE or other investigation to identify the cause(s) or toxicity,
  - b. Actions the Discharger has taken/will take to mitigate the impact of the discharge and to prevent the recurrence of toxicity.

When corrective actions, including a TRE have not been complete, a schedule under which corrective actions will be implemented, or the reason for not taking corrective action, if no action has been taken.

**VI. LAND DISCHARGE MONITORING REQUIREMENTS – NOT APPLICABLE**

**VII. RECYCLING MONITORING REQUIREMENTS**

The Discharger shall comply with the MRP (Attachment E) for reclaimed water production. The Discharger shall comply with applicable State and local monitoring requirements regarding the production and use of reclaimed wastewater, including requirements established by the SWRCB Division of Drinking Water (DDW) at title 22, sections 60301-60355 of the California Code of Regulations, Water Recycling Criteria. The Goleta Water District, as the primary user of reclaimed water, is responsible for the distribution and use of reclaimed water to the general public under Order No 97-06. The use of reclaimed water may alternatively be regulated by SWRCB General Water Reclamation Requirements for Recycled Water Use.

**VIII. RECEIVING WATER MONITORING REQUIREMENTS**

**A. Surf-Zone Monitoring**

If three consecutive effluent total coliform and/or fecal coliform bacteria tests, in any combination, exceed 16,000 per 100 mL or 3,200 per 100 mL, respectively, samples of the receiving water shall be collected at monitoring stations A, A1, A2, B, C, D, and E and analyzed as specified in Table E-6:

**Table E-6. Surf Zone Monitoring**

Parameter	Units	Sample Type	Minimum Frequency of Sampling/Analysis
Total Coliform	MPN/100 mL	Grab	1/Week
Fecal Coliform	MPN/100 mL	Grab	1/Week
Enterococcus	MPN/100 mL	Grab	1/Week
Temperature	°C	Grab	1/Week

Monitoring shall include observations of wind (direction and speed), weather (e.g., cloudy, sunny, rainy), sea state (height of swells and waves), longshore current (e.g., direction), tidal condition (high, slack, low), water discoloration, floating grease and oil, turbidity, odor, and



materials of sewerage origin in the water shall be recorded and reported. Surf-zone samples shall be collected as far seaward as possible within the surf-zone.

Surf-zone monitoring determines compliance with water quality standards, assesses bacteriological conditions in areas used for water contact recreation, where shellfish and/or kelp may be harvested for human consumption, and assesses aesthetic conditions for general recreational uses. Monitoring shall continue until the effluent bacteria concentrations return to compliance for a minimum of 14-days. Samples influenced by discharges from Goleta Slough, flood control channels, or samples collected on a rainy day and up to three days after a large rain are excluded from the calculation of compliance with receiving water limits.

#### **B. Notification and Monitoring Procedure in the Event of Disinfection Failure**

Additionally, surf-zone monitoring sites shall be monitored for seven days when there is a continuous loss of disinfection of 12 hours or longer and the Discharger shall report the results to the Executive Officer within 24 hours after receiving them from the laboratory. The Discharger shall notify the California Department of Public Health Preharvest Shellfish Sanitation Unit (CDPH), the Regional Water Board, the Santa Barbara County Environmental Health Services Department, and each certified commercial shellfish grower located in the Santa Barbara Nearshore Aquaculture Area as set forth in a list provided by CDPH, in the event of operational changes, plant upsets, process failures, or effluent violations that are likely to increase bacterial concentrations (hereinafter Event). Such notification by the Discharger shall be by phone to the numbers provided to the Discharger by CDPH. If the Discharger becomes aware of the Event between the hours of 6:00 a.m. and 5:00 p.m., notification shall be given within four (4) hours of the time that the Discharger becomes aware of the Event. If the Discharger becomes aware of the Event after 5:00 p.m., notification shall be given by 10:00 a.m. the next day.

By providing notification of an Event as specified above, the Discharger shall not be deemed to have concluded that the Event will or may impact any commercial shellfish growing areas or require the closure of any growing areas. Any decision or recommendation to close a growing area in response to a notification of an Event by the Discharger shall be made by CDPH and/or the affected or potentially affected certified commercial shellfish grower(s). The Discharger shall have no liability (including but not limited to liability for lost sales/profits or interpretation of business operations) arising from a decision by CDPH or a shellfish grower to close a growing area in response to a notification of an Event where no actual adverse impact on the growing area from the Event has been established. Each certified commercial shellfish grower located in the Santa Barbara Nearshore Aquaculture Area shall execute a written document acknowledging the foregoing limitation on the Discharger's liability in connection with its Event notification obligations set forth above, and the Discharger shall not be required to provide any notification of an Event to any shellfish grower who fails to execute such written acknowledgement.

### **IX. BENTHIC MONITORING**

- A.** Benthic Sediment Monitoring shall be conducted in 2019 at stations B1, B2, B3, B4, B5, and B6 to assess the temporal and spatial occurrence of pollutants in local marine sediments and to evaluate the physical and chemical quality of the sediments in relation to the outfall. At stations B1, B2, B3, B4, B5, and B6, one (1) grab sample shall be collected using a 0.1 m<sup>2</sup>

modified Van Veen grab sampler; the top 2 cm of materials from each grab sample shall be analyzed individually for the following parameters:

**Table E-8. Benthic Sediment Monitoring**

Parameter	Units
Sediment particle size <sup>2</sup>	phi size (% volume)
Grease and Oil	µg/g
Total Kjeldahl Nitrogen	µg/g
Total Organic Carbon	µg/g
Acid Volatile Sulfide	µg/g
Aluminum	µg/g
Antimony	µg/g
Arsenic	µg/g
Cadmium	µg/g
Chromium	µg/g
Copper	µg/g
Iron	µg/g
Lead	µg/g
Mercury	µg/g
Nickel	µg/g
Selenium	µg/g
Silver	µg/g
Tin	µg/g
Zinc	µg/g
Aldrin	ng/g
Chlordane <sup>3</sup>	ng/g
DDT <sup>4</sup>	ng/g
Dieldrin	ng/g
Heptachlor <sup>5</sup>	ng/g
Heptachlor <sup>25</sup> epoxide	ng/g
Hexachlorobenzene	ng/g

<sup>2</sup> Report percent (%) weight in relation to phi size.

<sup>3</sup> CHLORDANE shall mean the sum of chlordane-alpha, chlordane-gamma, chlordene-alpha, chlordene-gamma, nonachlor-alpha, nonachlor-gamma, and oxychlordane.

<sup>4</sup> DDT shall mean the sum of 4,4'-DDT, 2,4'-DDT, 4,4'-DDE, 2,4'-DDE, 4,4'-DDD, and 2,4'-DDD.

<sup>5</sup> HEPTACHLOR formerly meant the sum of heptachlor and heptachlor epoxide – each specie is now listed.

Parameter	Units
HCH <sup>6</sup>	ng/g
Mirex	ng/g
PAHs <sup>7</sup>	ng/g
1-methylnaphthalene	ng/g
1-methylphenanthrene	ng/g
2-methylnaphthalene	ng/g
2,6-dimethylnaphthalene	ng/g
1,6,7-trimethylnaphthalene	ng/g
Acenaphthene	ng/g
Biphenyl	ng/g
Naphthalene	ng/g
Benzo(a)anthracene	ng/g
Benzo(b)fluoranthene	ng/g
Benzo(e)pyrene	ng/g
Benzo(ghi)perylene	ng/g
Fluoranthene	ng/g
Perylene	ng/g
PCBs <sup>8</sup>	ng/g

Sediment samples analyzed for parameters other than organic priority pollutants shall be placed in air-tight polyethylene or glass containers. Separate subsamples for dissolved sulfides analysis shall be placed in small (100-200 mL) wide-mouth bottles and preserved with zinc acetate. The preservative must be carefully mixed with the sediment sample. Sediment samples collected for organic priority pollutant analysis should be placed in air-tight glass containers. All containers should be completely filled by the sediment sample and air bubbles should not be trapped in the containers. Samples shall be stored immediately at 2 to 4°C and not frozen or dried. Total sample storage time shall not exceed two (2) weeks.

When processing samples for analysis, macrofauna and large remnants greater than 0.25 inches (0.64 cm) should be removed, taking care to avoid contamination.

<sup>6</sup> HCH shall mean the sum of the alpha, beta, gamma (lindane), and delta isomers of hexachlorocyclohexane.

<sup>7</sup> PAHs (polynuclear aromatic hydrocarbons) shall mean the sum of acenaphthylene, anthracene, 1,2-benzanthracene, 3,4-benzofluoranthene, benzo[k]fluoranthene, 1,12-benzoperylene, benzo[a]pyrene, chrysene, dibenzo[ah]anthracene, fluorene, indeno[1,2,3-cd]pyrene, phenanthrene, and pyrene.

<sup>8</sup> PCBs (polychlorinated biphenyls) shall mean the sum of chlorinated biphenyls whose analytical characteristics resemble those of Aroclor-1016, Aroclor-1221, Aroclor-1232, Aroclor-1242, Aroclor-1248, Aroclor-1254 and Aroclor-1260.

Sediment samples shall be analyzed according to Quality Assurance and Quality Control (QA/QC) for 301(h) Monitoring Programs: Guidance on Field and Laboratory Methods (EPA 430/9-86-004, 1987) and Analytical Methods for EPA Priority Pollutants and 301(h) Pesticides in Estuarine and Marine Sediments (EPA 503-6-90-004), 1986), or the most recent editions.

All sediment results shall be reported in the raw form and expressed on a dry weight basis. For all non-detect results, parameter detection limits shall be reported. Dry weight concentration target detection levels are indicated for National Oceanic and Atmospheric Administration (NOAA) National Status and Trends Program analyses.

Chemical results normalized to the percent fine sediment fraction (i.e., phi 4), total organic carbon (TOC), etc., for analytical comparisons are calculated as follows:

$$\text{normalized result} = \frac{\text{raw result}}{\% \text{ X (as a decimal)}}$$

A benthic monitoring report will be submitted to the Executive Officer within six months of sampling. The report on benthic monitoring shall include a complete discussion of benthic sediment survey results and (possible) influence of the discharge on sediment conditions in the study area. The discussion should be based on graphical, tabular, and/or appropriate statistical analyses of spatial and temporal patterns observed for raw and normalized sediment parameters. The report should also present an analysis of natural variation in sediment conditions, etc., which could influence the validity of study results. The Discharger's sediment results may also be compared with the results of other applicable studies, numeric protective levels, etc., as appropriate. Survey results shall be compared to pre-discharge and/or historical data using appropriate statistical methods.

#### **A. Benthic Community Monitoring**

Benthic infaunal organisms shall be monitored in 2019 at the benthic monitoring stations described in Section II, *Monitoring Locations*, above. Benthic infaunal monitoring shall assess the temporal and spatial status of local benthic communities in relation to the outfall. Sampling shall be conducted as follows:

1. Collection: Five replicate samples shall be collected at each station using a 0.1 m<sup>2</sup> Van Veen grab sampler.
2. For benthic infauna analyses, each replicate sample shall be passed through a 1 mm screen, and the organisms retained and preserved as appropriate for subsequent identification. It is recommended that sample preservation, sample processing, and data analyses be conducted according to Quality Assurance and Quality Control (QA/QC) for 301(h) Monitoring Programs: Guidance on Field and Laboratory Methods (EPA 430/9-86-004, 1987).
3. Benthic infauna from each replicate sample shall be counted and identified to the lowest possible taxon. For each replicate sample, number of individuals, number of species, and number of individuals per species, and within each major taxonomic group (polychaetes, molluscs, crustaceans, echinoderms, and all other macroinvertebrates) shall be recorded.
4. The names and qualifications of persons handling and identifying benthic fauna shall be given in all data reports. A voucher collection shall be established containing a sample of each taxon identified to species. These vouchers will be maintained by the Discharger during this permit

period and deposited in archival institutions at permit termination. All remaining organisms from infaunal samples will be stored as separate replicate samples by the Discharger for ten (10) years after the effective date of this permit.

A benthic monitoring report will be submitted to the Executive Officer within six months of sampling. The report shall include a complete discussion of benthic infaunal survey results and (possible) influence of the outfall on benthic infauna communities in the study area. The discussion should be based on graphical, tabular, and/or appropriate statistical analyses of spatial and temporal patterns. Temporal trends in the number of individuals, number of species, number of individuals per species, and community structure indices, species richness (S), Margalef index (d), Shannon-Wiener index (H'), Brillouin index (h), Simpson's Index (SI), Swartz's dominance, Benthic Response Index (BRI), and Infaunal Trophic Index (ITI) shall be reported. Classification analyses, using Bray-Curtis similarity index, and the group average clustering strategy, or the flexible sorting strategy, should be conducted. The report should also present an analysis of natural community variation including the effects of different sediment conditions, oceanic seasons, and water temperatures, etc., that could influence the validity of study results. Survey results shall be compared to pre-discharge and/or historical data using appropriate statistical methods.

## **X. DATA ANALYSIS**

Data analyses which may be required to determine temporal and spatial trends (within " and between stations) in the marine environment include:

- A. Graphical and/or Tabular Analyses.** Shall include station means, ranges, standard deviations, and 95% confidence limits.
- B. Univariate Statistical Analyses**
  - 1. Analysis of Variance (ANOVA) -parametric test
  - 2. Kruskal-Wallis test -nonparametric test
  - 3. Other test methods as appropriate
- C. Multivariate Statistical Analyses**
  - 1. Classification analyses -similarity and cluster analyses
  - 2. Other test methods as appropriate
- D. Biological Indices**
  - 1. Species richness (S) -species number
  - 2. Margalef's species richness (d) -measure of species number
  - 3. Shannon-Wiener diversity (H) -combined measure of species and evenness
  - 4. Brillouin diversity (H) -combined measure of species and evenness
  - 5. Simpson's Index (SI) -measure of dominance
  - 6. Swartz's dominance -measure of dominance
  - 7. Infaunal Trophic Index (ITI) -Southern California Bight benthic infauna only
  - 8. Benthic Response Index (BRI) -average pollutant tolerance

## XI. BIOSOLIDS MONITORING

- A.** The following information shall be submitted with the annual report. Adequate detail shall be included to characterize biosolids in accordance with 40 CFR Part 503.
1. Annual biosolids production in dry tons and percent solids.
  2. A schematic drawing showing biosolids handling facilities (e.g., digesters, lagoons, drying beds, incinerators) and a solids flow diagram.
  3. A narrative description of biosolids dewatering and other treatment processes, including process parameters. For example, if biosolids are digested, report average temperature and retention time of the digesters. If drying beds are used, report depth of application and drying time. If composting is used, report the temperature achieved and duration.
  4. A description of disposal methods, including the following information as applicable related to the disposal methods used at the facility. If more than one method is used, include the percentage and tonnage of annual biosolids production disposed by each method.
    - a. For landfill disposal include:
      - i. The Central Coast Water Board WDR numbers that regulate the landfills used,
        - (a) The present classifications of the landfills used, and 3) the names and locations of the facilities receiving biosolids.
      - ii. For land application include:
        - (a) The location of the site(s),
        - (b) The Central Coast Water Board's WDR numbers that regulate the site(s),
        - (c) The application rate in lbs/acre/year (specify wet or dry), and
        - (d) Subsequent uses of the land.
      - iii. For offsite application by a licensed hauler and composter include:
        - (a) The name, address and USEPA license number of the hauler and composter.
    - b. Copies of analytical data required by other agencies (i.e., USEPA or County Health Department) and licensed disposal facilities (i.e., landfill, land application, or composting facility) for the previous year.
- B.** A representative sample of residual solids (biosolids) shall be obtained from the last point in the handling process (i.e., in the drying beds just prior to removal) and shall be analyzed for total concentrations for comparison with Total Threshold Limit Concentration (TTLC) criteria. The Waste Extraction Test shall be performed on any constituent when the total concentration of the waste exceeds ten times the Soluble Threshold Limit Concentration (STLC) limit for that substance. Twelve (12) discrete representative samples shall be collected at separate locations in the biosolids ready for disposal. These 12 samples shall be composited to form one (1) sample for constituent analysis. For accumulated, previously untested biosolids, the Discharger shall develop a representative sampling plan including number and location of sampling points, and collect representative samples.

**Table E-9. Biosolids Monitoring Requirements**

Parameter	Units	Sample Type	Minimum Frequency of Sampling/Analysis
Quantity Removed	tons or yards <sup>(1)</sup>	Measured	Continual
Pathogen Density	---	---	Per 40 CFR 503
Location of Reuse/Disposal	General public or specific site	---	1/Year
Moisture Content	percent	Grab	1/Quarter
Total Kjeldahl Nitrogen	mg/kg (dry) <sup>1</sup>	Grab	1/Quarter
Ammonia (as N)	mg/kg	Grab	1/Quarter
Nitrate (as N)	mg/kg	Grab	1/Quarter
Total Phosphorus	mg/kg	Grab	1/Quarter
Arsenic	mg/kg	Grab	1/Quarter
Boron	mg/kg	Grab	1/Quarter
Cadmium	mg/kg	Grab	1/Quarter
Copper	mg/kg	Grab	1/Quarter
Chromium	mg/kg	Grab	1/Quarter
Lead	mg/kg	Grab	1/Quarter
Nickel	mg/kg	Grab	1/Quarter
Mercury	mg/kg	Grab	1/Quarter
Molybdenum	mg/kg	Grab	1/Quarter
Selenium	mg/kg	Grab	1/Quarter
Silver	mg/kg	Grab	1/Quarter
Zinc	mg/kg	Grab	1/Quarter
pH	standard units	Grab	1/Year
Oil and Grease	mg/kg	Grab	1/Year
Priority Pollutants (excluding asbestos)	mg/kg	Grab	1/Year

<sup>(1)</sup> Total sample (including solids and any liquid portion) to be analyzed and results reported as mg/kg based on the dry weight of the sample.

- C.** Prior to land application, the Discharger shall demonstrate that the biosolids meet Class A or Class B pathogen reduction levels by one of the methods listed in 40 CFR 503.32 (unless transferred to another preparer who demonstrates pathogen reduction). Prior to disposal in a surface disposal site, the Discharger shall demonstrate that the biosolids meet Class B levels or shall ensure that the site is covered at the end of each operating day. If pathogen reduction is demonstrated using a "Process to Significantly/Further Reduce Pathogens "(PFRP), the Discharger shall maintain daily records of the operating parameters to achieve this reduction.

The following applies when biosolids from the Discharger are directly land applied as Class B, without further treatment by a second preparer. If the Discharger demonstrates pathogen reduction by direct testing for fecal coliforms and/or pathogens, samples must be drawn at the frequency in the Amount/Frequency table above. If the Discharger demonstrates Class B pathogen reduction by testing for fecal coliform, at least seven grab samples must be drawn and analyzed during each monitoring event, and a geometric mean calculated from these seven samples. If the Discharger demonstrates Class A pathogen reduction by testing for fecal coliform and/or salmonella, plus one of the PFRP processes or testing for enteric viruses and helminth ova at least four samples of fecal coliform or salmonella must be drawn during each monitoring event. All four samples must meet the limits specified in 40 CFR 503.32(a).

- D.** For biosolids that are land applied or placed in a surface disposal site, the Discharger shall track and keep records of the operational parameters used to achieve Vector Attraction Reduction requirements in 40 CFR 503.33(b).

- E.** Class 1 facilities (facilities with pretreatment programs or others designated as Class 1 by the regional Administrator) and Federal facilities with greater than five MGD influent flow shall sample biosolids for pollutants listed under Section 307(a) of the CWA (as required in the pretreatment section of the permit for POTWs with pretreatment programs). Class 1 facilities and Federal facilities greater than 5 MGD shall test dioxins/dibenzofurans using a detection limit of less than one pg/g at the time of their next priority pollutant scan if they have not done so within the past five years, and once per five years thereafter.
- F.** The biosolids shall be tested annually, or more frequently if necessary, to determine hazardousness. All constituents regulated under CCR Title 22, division 5, chapter 11, article 3 shall be analyzed for comparison with criteria. The Waste Extraction Test shall be performed on any constituent when the total concentration of the waste exceeds ten times the STLC limit for that substance.
- G.** If biosolids are placed in a surface disposal site (dedicated land disposal site or monofill), a qualified groundwater scientist shall develop a groundwater monitoring program for the site, or shall certify that the placement of biosolids on the site will not contaminate an aquifer.
- H.** Biosolids placed in a municipal landfill shall be tested by the Paint Filter Liquids Test (EPA Method 9095) at the frequency determined by 40 CFR Part 503, or more often if necessary to demonstrate that there are no free liquids.

The Discharger, either directly or through contractual agreements with their biosolids management contractors, shall comply with the following notification requirements:

- 1.** Notification of non-compliance. The Discharger shall notify USEPA Region 9, the Regional Water Board, and the Regional Water Board located in the region where the biosolids are used or disposed, of any non-compliance within 24 hours if the non-compliance may seriously endanger health or the environment. For other instances of non-compliance, the Discharger shall notify USEPA Region 9 and the affected Regional Water Boards of any non-compliance in writing within five working days of becoming aware of the non-compliance. The Discharger shall require their biosolids management contractors to notify USEPA Region 9 and the affected Regional Water Boards of any non-compliance within the same time frames.
- 2.** If biosolids are shipped to another state or Indian lands, the Discharger must send notice at least 60 days prior to the shipment to the permitting authorities in the receiving State or Indian land (the USEPA Regional Office for that area and the State/Indian authorities).
- 3.** For land application (in cases where Class B biosolids are directly applied without further treatment): Prior to reuse of any biosolids from the Discharger's facility to a new or previously unreported site, the Discharger shall notify EPA, the Regional Water Board, and any other affected Regional Water Board. The notification shall include description of the crops or vegetation to be grown, proposed loading rates and determination of agronomic rates.

If any biosolids within a given monitoring period do not meet 40 CFR 503.13 metals concentrations limits, the Discharger (or its contractor) must pre-notify USEPA, and determine the cumulative metals loading to that site to date, as required in 40 CFR 503.12. The Discharger shall notify the applier of all the applier's requirements under 40 CFR 503, including the requirement that the applier certify that the management practices, site restrictions, and any applicable vector attraction reduction requirements have been met. The Discharger shall require the applier to certify at the end of 38 months following application of Class B biosolids that the harvesting restrictions in effect for up to 38 months have been met.



4. For surface disposal: Prior to disposal to a new or previously unreported site, the Discharger shall notify USEPA and the Regional Water Board. The notice shall include a description and a topographic map of the proposed site, depth to groundwater, whether the site is lined or unlined, site operator, site owner, and any State or local permits. The notice shall describe procedures for ensuring public access and grazing restrictions for three years following site closure. The notice shall include a groundwater monitoring plan or description of why groundwater monitoring is not required.
- I. The Discharger shall submit an annual biosolids report to the USEPA Region 9 Biosolids Coordinator and Regional Water Board by February 19th of each year (per USEPA guidance and 40 C.F.R. 503) for the period covering the previous calendar year. This report shall include:
1. Annual biosolids removed in dry tons and percent solids.
  2. If appropriate, a narrative description of biosolids dewatering and other treatment processes, including process parameters, including a schematic diagram showing biosolids handling facilities. For example, if drying beds are used, report depth of application and drying time. If composting is used, report the temperature achieved and duration.
  3. A description of disposal methods, including the following information as applicable related to the disposal methods used at the facility. If more than one method is used, include the percentage and tonnage of annual biosolids production disposed by each method.
    - a. For landfill disposal include: 1) the Regional Water Board WDR numbers that regulate the landfills used, 2) the present classifications of the landfills used, 3) the results of any groundwater monitoring, 4) certifications of management practices, and 5) the names and locations of the facilities receiving biosolids.
    - b. For land application include: 1) the location of the site(s), 2) the Regional Water Board's WDR numbers that regulate the site(s), 3) the application rate in lbs/acre/year (specify wet or dry), 4) certifications of management practices and site restrictions, and 5) subsequent uses of the land.
    - c. For offsite application by a licensed hauler and composter include: 1) the name, address and USEPA license number of the hauler and composter.
  4. Copies of analytical data required by other agencies (i.e. USEPA or county health department) and licensed disposal facilities (i.e. landfill, land application, or composting facility) for the previous year.
  5. Descriptions of pathogen reduction methods and vector attraction reduction methods. Including supporting time and temperature data, and certifications, as required in 40 CFR 503.17 and 503.27.
  6. Names, mailing address, and street addresses of persons who received biosolids for storage, further treatment, disposal in a municipal waste landfill, or for other use or disposal methods not covered above, and amounts delivered to each.
  7. For all biosolids used or disposed at the Discharger's facility, the site and management practice information and certification required in 40 CFR 503.17 and 503.27.
  8. For all biosolids temporarily stored, the information required in 40 CFR 503.20 is required to demonstrate temporary storage.
  9. Reports shall be submitted to:

Regional Biosolids Coordinator  
 USEPA (WTR-7)  
 75 Hawthorne St.  
 San Francisco, CA 94105-3901

Executive Officer  
 Central Coast Regional Water Quality Control Board  
[centralcoast@waterboards.ca.gov](mailto:centralcoast@waterboards.ca.gov)

**XII. RECLAIMED WATER MONITORING**

**A. Influent Monitoring**

Representative samples of the influent shall be monitored for:

**Table E-10. Reclaimed Water Influent Monitoring**

Parameter	Units	Type of Sample
Daily Flow Volume	Gal/day	Metered
Maximum Daily Flow	Gal/day	---
Mean Daily Flow	Gal/day	Calculated

**B. Reclaimed Water Monitoring**

Representative samples of the influent shall be monitored for:

**Table E-11. Reclaimed Water Effluent Monitoring – Discharge Point 002**

Parameter	Units	Type of Sample	Minimum Sampling and Analyzing Frequency
Daily Flow	gal/day	Metered	continuous
Turbidity <sup>1</sup>	NTU	Metered	Continuous
Chlorine Residual <sup>2</sup>	mg/L	Metered	Continuous
Total Coliform Organisms	MPN/100 ml	Grab	Daily
Total Suspended Solids	mg/L	24 hr. composite	Five days a week
pH	pH Units	Grab	Daily
Biochemical Oxygen Demand	mg/L	24 hr. composite	Monthly
Total Dissolved Solids	mg/L	24 hr. composite	Quarterly <sup>3</sup>
Cadmium	mg/L	24 hr. composite	Semi-Annually <sup>4</sup>
Lead	mg/L	24 hr. composite	Semi-Annually <sup>4</sup>

<sup>1</sup> Report daily maximum and daily mean values. In reporting turbidity, the amount of time that 5 Nephelometric Turbidity Units (NTU) was exceeded each day shall be reported. Turbidity samples shall be obtained after filtration and before reclaimed water enters the chlorine contact chamber.

<sup>2</sup> Report daily maximum and daily minimum values. Compliance shall be determined by daily minimum values measured within the zone at the end of the chlorine contact chamber.

<sup>3</sup> January, April, July, and October of each calendar year.

<sup>4</sup> April and October of each calendar year.

### **C. Reclaimed Water Reporting**

Reports shall be submitted by the 20<sup>th</sup> day of the month and shall include for the previous month the following:

1. Results of influent and reclaimed water monitoring;
2. A summary of operational problems, reclamation plant and equipment malfunctions, and any diversion of reclaimed water to the Goleta Sanitary District Water Resource Recovery Facility;
3. A record of equipment or process failures initiating an alarm, as well as any corrective and preventative measures taken; and,
4. A record of any employee or User training.

## **XIII. OTHER MONITORING REQUIREMENTS**

### **A. Ocean Outfall and Diffuser Inspection**

Annually (October), the Discharger shall conduct an inspection of the sewage outfall pipe/diffuser system to ensure the proper operation and structural integrity of the system (e.g., cracks, breaks, leaks, plugged ports, or other actual or potential malfunctions). The outfall inspection will also check for possible external blockage of ports by sand and/or silt deposition. This inspection shall include general observations and photographic records of the outfall pipe/diffuser system and the surrounding ocean bottom in the vicinity of the outfall/diffuser. The inspection shall be conducted along the outfall pipe/diffuser system from ocean terminus to landfall. A report detailing inspection results shall be submitted to the Regional Water Board and USEPA with the annual report (see "Standard Provisions and Reporting Requirements for National Pollutant Discharge Elimination System Permits," dated January 1985). The inspection shall be conducted during a time of good underwater visibility.

### **B. Pretreatment Monitoring and Reporting**

1. The Discharger shall submit an annual report to the State Water Board and USEPA describing its pretreatment activities over the previous year. In the event that the Discharger is not in compliance with any conditions or requirements of this permit affected by the pretreatment program, including any noncompliance with pretreatment audit or compliance inspection requirements, then the Discharger shall also include the reasons for noncompliance and state how and when the Discharger shall comply with such conditions and requirements. This annual report shall cover operations from January 1st through December 31st and is due on March 1st of each year. The report shall contain, but not be limited to, the following information:
  - a. A summary of analytical results from representative, flow-proportioned, 24-hour composite sampling of the Discharger's influent and effluent for those pollutants USEPA has identified in Section 307(a) of the CWA. This will consist of an annual full priority pollutant scan. The Discharger is not required to sample and analyze for asbestos.

A summary of analytical results from representative samples of the treatment facility's biosolids shall also be provided. The biosolids analyzed shall be a composite sample of a minimum of twelve discrete sub-samples (grab samples) taken at equal time intervals over a typical dewatering operational period up to 24 hours, and from the last representative point in the solids handling process before disposal (e.g., from drying beds, dewatered biosolids conveyor belt, etc.). Biosolids shall be sampled during the

same 24-hour period and analyzed for the same pollutants as the influent and effluent sampling and analysis. Wastewater and biosolids sampling and analysis shall be performed a minimum of annually and not less than the frequency otherwise specified in this monitoring program. The Discharger shall also provide any influent, effluent, or biosolids monitoring data for non-priority pollutants which the Discharger believes may be causing or contributing to interference, pass-through, or adversely impacting biosolids quality. Sampling and analysis shall be performed in accordance with the techniques prescribed in 40 CFR Part 136 and amendments thereto. Biosolids results shall be expressed in mg/kg dry biosolids.

- b.** A discussion of Upset, Interference, or Pass-Through incidents, if any, at the treatment plant which the Discharger knows or suspects was caused by industrial users of the POTW system. The discussion shall include the reasons why the incidents occurred, the corrective actions taken and, if known, the name and address of the nondomestic user(s) responsible. The discussion shall also include a review of the applicable pollutant limitations to determine whether any additional limitations, or changes to existing requirements, may be necessary to prevent Pass-Through, Interference, or noncompliance with biosolids disposal/reuse requirements.
- c.** An updated list of the Discharger's significant industrial users (SIUs) including their names and addresses, and a list of deletions, additions, and SIU name changes keyed to the previously submitted list. The Discharger shall provide a brief explanation for each deletion. The SIU list shall identify the SIUs subject to Federal Categorical Standards by specifying which set(s) of standards are applicable to each SIU. The list shall also indicate which SIUs are subject to local limitations.
- d.** The Discharger shall characterize the compliance status for each SIU by providing a list or table which includes:
  - i. SIU name;
  - ii. Industrial category, if subject to federal categorical standards;
  - iii. The type (processes) of wastewater treatment in place;
  - iv. Number of samples taken by the Discharger during the year;
  - v. Number of samples taken by the SIU during the year;
  - vi. Whether, for facilities which have limits for total toxic organics, all required certification; (if allowed) were provided;
  - vii. Standards violated during the year (categorical standards and local limits, reported separately);
  - viii. Whether the facility was in Significant Noncompliance (SNC), as defined by 40 CFR 403.12(f)(2)(vii), at any time during the year [SNC is determined at the beginning of each quarter based on data of the previous six (6) months]; and
  - ix. A summary of enforcement actions taken during the year, including the type of action, final compliance date, and amount of fines assessed/collected (if any). Proposed actions for bringing the SIU into compliance, if known, should be included.

- e. A brief description of any programs the POTW implements to reduce pollutants from nondomestic users that are not classified as SIUs.
  - f. A short description of any significant changes in operating the pretreatment program which differ from the previous year including, but not limited to, changes concerning: the program's administrative structure; local limits; monitoring program or monitoring frequencies; legal authority or enforcement policy; funding mechanisms, funding levels; or staffing levels.
  - g. A summary of the annual pretreatment budget, including the cost of pretreatment program functions and equipment purchases.
  - h. A summary of public participation activities to involve and inform the public, including a copy of the newspaper notice, if any, required under 40 CFR 403.8.
  - i. A description of any changes in biosolids disposal reuse methods and a discussion of any concerns not described elsewhere in the report.
2. Semiannual reports. The Discharger shall submit a semiannual SIU noncompliance status report to EPA Pacific Southwest Region, and the State. The report shall cover the period of January 1 through June 30, and shall be submitted by July 31. The report shall contain the following:
- a. The name and address of all SIUs which violated any discharge or reporting requirements during the report period;
  - b. A description of the violations including whether any discharge violations were for categorical standards or local limits;
  - c. A description of the enforcement or other actions that were taken to remedy the noncompliance; and
  - d. The status of active enforcement and other actions taken in response to SIU noncompliance identified in previous reports.

Reports shall be signed by a principal executive officer, ranking elected official, or other duly authorized employee if such employee is responsible for overall operation of the POTW. Signed copies of these reports shall be submitted to the USEPA and the State at the following addresses:

California Regional Water Quality Control Board  
Central Coast Region  
[centralcoast@waterboards.ca.gov](mailto:centralcoast@waterboards.ca.gov)

State Water Resources Control Board  
Regulation Unit  
P.O. Box 100  
Sacramento, CA 95812-0100

#### **XIV. REPORTING REQUIREMENTS**

##### **A. General Monitoring and Reporting Requirements**

The Discharger shall comply with all Federal Standard Provisions and Central Coast Water Board Standard Provisions (Attachment D) related to monitoring, reporting, and recordkeeping.

**B. Self-Monitoring Reports (SMR's)**

1. The Discharger shall electronically submit SMR's using the State Water Board's California Integrated Water Quality System (CIWQS) Program Web site (<http://www.waterboards.ca.gov/ciwqs/index.html>). The CIWQS Web site will provide additional information for SMR submittal in the event there will be a planned service interruption for electronic submittal. The Discharger shall use the current version of the Permittee Entry Template (PET) tool to configure data into the applicable CIWQS Data Format, and shall update that template according to this Order (e.g., add/delete parameters, revise limits, update monitoring locations, etc.). Blank versions of the latest PET tool are available at [http://www.waterboards.ca.gov/water\\_issues/program/ciwqs/chc\\_npdes.shtml](http://www.waterboards.ca.gov/water_issues/program/ciwqs/chc_npdes.shtml).
2. The Discharger shall report in the SMR the results for all monitoring specified in this MRP under sections III through IX. The Discharger shall submit SMR's including the results of all required monitoring using U.S. EPA-approved test methods or other test methods specified in this Order. If the Discharger monitors any pollutant more frequently than required by this Order, the results of this monitoring shall be included in the calculations and reporting of the data submitted in the SMR.
3. Sampling and monitoring as required by this MRP shall begin on the effective date of this Order. The Discharger shall complete all required monitoring and reporting according to the following schedule unless otherwise directed by the Executive Officer:

**Table E-12. Monitoring Periods and Reporting Schedule**

Sampling Frequency	Monitoring Period Begins On	SMR Submittal Frequencies	SMR Due Date
Continuous	Effective permit date (see Table 3)	All	First day of the second month following the month of sampling (e.g., reports for sampling conducted in January are due no later than March 1)
1/Day	Effective permit date (see Table 3)	(Midnight through 11:59 PM) or any 24-hour period that reasonably represents a calendar day for purposes of sampling	Submit with monthly SMR
1/Week	Sunday following permit effective date or on permit effective date if on a Sunday	Sunday through Saturday	Submit with monthly SMR
1/Month	First day of calendar month following permit effective date or on permit effective date if that date is first day of the month	1 <sup>st</sup> day of calendar month through last day of calendar month	Submit with monthly SMR
1/Quarter	Closest of January 1, April 1, July 1, or October 1 following (or on) permit effective date	January 1 through March 31 April 1 through June 30 July 1 through September 30 October 1 through December 31	Submit with next monthly SMR

Sampling Frequency	Monitoring Period Begins On	SMR Submittal Frequencies	SMR Due Date
2/Year	Closest of January 1 or July 1 following (or on) permit effective date	January 1 through June 30 July 1 through December 31	Submit with next monthly SMR
1/Year	January 1 following (or on) permit effective date	January 1 through December 31	Submit with Annual Report
1/Permit Term	Between 180 and 365 days prior to Order expiration date	Permit term	The earliest of May 1, Aug 1, Nov 1, or Feb 1 following the monitoring event

4. Reporting Protocols. The Discharger shall report with each sample result the applicable reported Minimum Level (reported ML, also known as the Reporting Level, or RL) and the current Method Detection Limit (MDL), as determined by the procedure in 40 C.F.R. part 136. For each parameter identified in Table 1 of the Ocean Plan, the Discharger shall use a ML no greater than specified in Appendix II of the Ocean Plan.

The Discharger shall report the results of analytical determinations for the presence of chemical constituents in a sample using the following reporting protocols:

- a. Sample results greater than or equal to the reported ML shall be reported as measured by the laboratory (i.e., the measured chemical concentration in the sample).
- b. Sample results less than the reported ML, but greater than or equal to the laboratory’s MDL, shall be reported as “Detected, but Not Quantified,” or DNQ. The estimated chemical concentration of the sample shall also be reported.

For the purposes of data collection, the laboratory shall write the estimated chemical concentration next to DNQ as well as the words “Estimated Concentration” (may be shorted to “Est. Conc.”). The laboratory may, if such information is available, include numerical estimates of the data quality for the reported result. Numerical estimates of data quality may be percent accuracy ( $\pm$  a percentage of the reported value), numerical ranges (low to high), or any other means considered appropriate by the laboratory.

- c. Sample results less than the laboratory’s MDL shall be reported as “Not Detected,” or ND.
  - d. Dischargers are to instruct laboratories to establish calibration standards so that the ML value (or its equivalent if there is differential treatment of samples relative to calibration standards) is the lowest calibration standard. At no time is the Discharger to use analytical data derived from extrapolation beyond the lowest point of the calibration curve.
5. The Discharger shall submit SMRs in accordance with the following requirements:
    - a. The Discharger shall arrange all reported data in a tabular format. The data shall be summarized to clearly illustrate whether the facility is operating in compliance with interim and/or final effluent limitations. The Discharger is not required to duplicate the submittal of data that is entered in a tabular format within CIWQS. When electronic submittal of data is required and CIWQS does not provide for entry into a tabular

format within the system, the Discharger shall electronically submit the data in a tabular format as an attachment.

- b. The Discharger shall attach a cover letter to the SMR. The information contained in the cover letter shall clearly identify violations of the WDRs; discuss corrective actions taken or planned; and the proposed time schedule for corrective actions. Identified violations must include a description of the requirement that was violated and a description of the violation.
- c. The Discharger shall electronically submit SMRs using the State Water Board's California Integrated Water Quality System (CIWQS) Program website at <[http://www.waterboards.ca.gov/water\\_issues/programs/ciwqs/](http://www.waterboards.ca.gov/water_issues/programs/ciwqs/)>. The CIWQS website will provide additional information for SMR submittal in the event there will be a planned service interruption for electronic submittal.
- d. An Annual Self-Monitoring Report Summary shall be due on February 1 following each calendar year and shall include:
  - i. All data required by this MRP for the corresponding monitoring period, including appropriate calculations to verify compliance with effluent limitations.
  - ii. A discussion of any incident of non-compliance and corrective actions taken.

### **C. Discharge Monitoring Reports (DMR's)**

The Discharger shall electronically certify and submit Discharge Monitoring Reports (DMRs) together with SMRs using Electronic Self-Monitoring Reports module eSMR 2.5 or any upgraded version. Electronic DMR submittal shall be in addition to electronic SMR submittal. Information about electronic DMR submittal is available at the DMR website at: [http://www.waterboards.ca.gov/water\\_issues/programs/discharge\\_monitoring](http://www.waterboards.ca.gov/water_issues/programs/discharge_monitoring)

### **D. Other Reports**

1. The Discharger shall report the results of any special monitoring, TRES, or other data or information that results from the Special Provisions, section VI. C, of the Order. The Discharger shall submit such reports with the first monthly SMR scheduled to be submitted on or immediately following the report due date.



## ATTACHMENT F – FACT SHEET

### Contents

I.	Permit Information .....	F-3
II.	Facility Description.....	F-4
	A. Description of Wastewater and Biosolids Treatment.....	F-4
	B. Discharge Points and Receiving Waters .....	F-5
	C. Summary of Existing Requirements and Self-Monitoring Report (SMR) Data.....	F-5
	D. Compliance Summary.....	F-8
	E. Planned Changes.....	F-8
III.	Applicable Plans, Policies, and Regulations .....	F-8
	A. Legal Authorities .....	F-8
	B. State and Federal Laws, Regulations, Policies, and Plans.....	F-9
	C. Impaired Water Bodies on CWA 303(d) List.....	F-10
	D. Other Plans, Policies and Regulations.....	F-10
IV.	Rationale for Effluent Limitations and Discharge Specifications.....	F-11
	A. Discharge Prohibitions .....	F-11
	B. Technology-Based Effluent Limitations.....	F-12
	1. Scope and Authority.....	F-12
	2. Applicable Technology-Based Effluent Limitations.....	F-12
	C. Water Quality-Based Effluent Limitations.....	F-14
	1. Scope and Authority.....	F-14
	2. Applicable Beneficial Uses and Water Quality Criteria and Objectives.....	F-14
	3. Determining the Need for WQBELs.....	F-14
	4. WQBEL Calculations.....	F-20
	5. Whole Effluent Toxicity (WET).....	F-21
	D. Final Effluent Limitation Considerations .....	F-21
	1. Anti-Backsliding Requirements.....	F-21
	2. Antidegradation Policies.....	F-22
	3. Stringency of Requirements for Individual Pollutants.....	F-22
	4. Summary of Final Effluent Limitations – Discharge Point No. 001.....	F-22
	E. Interim Effluent Limitations → Not Applicable.....	F-26
	F. Land Discharge Specifications → Not Applicable.....	F-26
	G. Recycling Specifications.....	F-26
V.	Rationale for Receiving Water Limitations .....	F-27
	A. Surface Water.....	F-27
	B. Groundwater → Not Applicable.....	F-28
VI.	Rationale for Monitoring and Reporting Requirements.....	F-28
	A. Influent Monitoring.....	F-28
	B. Effluent Monitoring.....	F-28
	C. Whole Effluent Toxicity Testing Requirements .....	F-28
	D. Land Discharge Monitoring Requirements → Not Applicable.....	F-28
	E. Reclaimed Water Specifications .....	F-28
	F. Receiving Water Monitoring.....	F-29
	G. Other Monitoring Requirements.....	F-29
VII.	Rationale for Provisions.....	F-29
VIII.	Public Participation.....	F-31

**Tables**

Table F-1. Facility Information..... F-3  
Table F-2. Historic Effluent Limitations and Monitoring Data..... F-5  
Table F-3. Historic Effluent Limitations and Monitoring Data, Protection of Marine Aquatic Life ..... F-6  
Table F-4. Historic Effluent Limitations and Monitoring Data for Non-Carcinogens and Carcinogens. F-6  
Table F-5. Basin Plan Beneficial Uses..... F-9  
Table F-6. Ocean Plan Beneficial Uses ..... F-9  
Table F-7. Secondary Treatment Requirements..... F-12  
Table F-8. Technology-Based Effluent Limitations ..... F-13  
Table F-9. RPA Results..... F-17  
Table F-10. Pollutants Having Background Concentrations..... F-21  
Table F-11. Final Effluent Limitations..... F-22  
Table F-12. Final Effluent Limitations, Protection of Marine Aquatic Life..... F-23  
Table F-13. Final Effluent Limitations – Protection of Human Health – Non-Carcinogens..... F-24  
Table F-14. Final Effluent Limitations – Protection of Human Health – Carcinogens ..... F-24

**ATTACHMENT F – FACT SHEET**

As described in section II.B of the Order, the Central Coast Water Board incorporates this Fact Sheet as findings of the Central Coast Water Board supporting the issuance of this Order. This Fact Sheet includes the legal requirements and technical rationale that serve as the basis for the requirements of this Order.

This Order has been prepared under a standardized format to accommodate a broad range of discharge requirements for Dischargers in California. Only those sections or subsections of this Order that are specifically identified as “not applicable” have been determined not to apply to this Discharger. Sections or subsections of this Order not specifically identified as “not applicable” are fully applicable to this Discharger.

**I. PERMIT INFORMATION**

The following table summarizes administrative information related to the facility.

**Table F-1. Facility Information**

<b>WDID</b>	3 420102001
<b>Discharger</b>	Goleta Sanitary District
<b>Name of Facility</b>	Goleta Sanitary District Water Resource Recovery Facility
<b>Facility Address</b>	One William Moffett Place
	Goleta, CA 93117
	Santa Barbara County
<b>Facility Contact, Title and Phone</b>	Steve Wagner, General Manager, (805) 967-4519
<b>Authorized Person to Sign and Submit Reports</b>	Steve Wagner, General Manager, (805) 967-4519
<b>Mailing Address</b>	One William Moffett Place, Goleta, CA 93117
<b>Billing Address</b>	Same as mailing address
<b>Type of Facility</b>	POTW
<b>Major or Minor Facility</b>	Major
<b>Threat to Water Quality</b>	2
<b>Complexity</b>	A
<b>Pretreatment Program</b>	Yes
<b>Recycling Requirements</b>	3.3 million gallons per day (MGD)
<b>Facility Permitted Flow</b>	7.64 MGD
<b>Facility Design Flow</b>	9.8 MGD
<b>Watershed</b>	Goleta Slough
<b>Receiving Water</b>	Pacific Ocean
<b>Receiving Water Type</b>	Ocean waters

- A.** The Goleta Sanitary District (hereinafter Discharger) is the owner and operator of a municipal wastewater treatment plant that treats wastewater from the service areas of the Goleta Sanitary District, the Goleta West Sanitary District, the University of California at Santa Barbara, the Santa Barbara Municipal Airport, and certain Santa Barbara County facilities. The Discharger also produces tertiary-treated recycled water for landscape irrigation and other incidental uses.

For the purposes of this Order, references to the “discharger” or “permittee” in applicable federal and state laws, regulations, plans, or policy are held to be equivalent to references to the Discharger herein.

- B.** The Facility discharges wastewater to the Pacific Ocean, a water of the United States. The Discharger was previously regulated by Order No. R3-2010-0012 and National Pollutant Discharge Elimination System (NPDES) Permit No. CA0048160, which was adopted on May 13, 2010, and expired on September 1, 2015. The terms and conditions of the current Order have been automatically continued and remain in effect until new waste discharge requirements and NPDES permit are adopted pursuant to this Order. Attachment B provides a map of the area around the Facility. Attachment C provides a flow schematic of the Facility.

Prior to making any change in the point of discharge, place of use, or purpose of use of treated wastewater that results in a decrease of flow in any portion of a watercourse, the Discharger must file a petition with the State Water Board Division of Water Rights and receive approval for such a change. The State Water Board retains the jurisdictional authority to enforce such requirements under Water Code section 1211.

- C.** The Discharger filed a report of waste discharge and submitted an application for reissuance of its waste discharge requirements and NPDES permit on March 5, 2015.

## II. FACILITY DESCRIPTION

### A. Description of Wastewater and Biosolids Treatment

- 1. Location and Service Areas.** The Facility is located at One William Moffett Place in an unincorporated area of Santa Barbara County, California. The plant site is approximately 10 miles west of the City of Santa Barbara, near the Pacific Coast. The Facility provides secondary level treatment for the Goleta Sanitary District, the Goleta West Sanitary District, University of California, Santa Barbara, and the Santa Barbara Airport, which each have separate collection systems. The total population served is estimated to be 97,238.
- 2. Collection System.** Over 190 miles of pipelines collect wastewater that flows almost entirely by gravity to pump stations located in each agency's service area. These stations pump the flow to the treatment facility.
- 3. Wastewater Treatment.** Influent from the collection system of each agency is pumped to the treatment plant headworks where raw wastewater flows through a bar screen that removes large debris. Influent is then routed to aerated grit tanks where sand and grit are allowed to settle out, then are dewatered and sent to a landfill. Wastewater then flows into one of three primary clarifiers where solids settle to the bottom and floatable materials are mechanically collected and pumped to the digesters.

The Discharger completed a substantial upgrade of the Facility in December 2013, allowing the plant to achieve full secondary treatment. The primary effluent moves to a biofilter to trickle over plastic media where bacteria feed on organic wastes and then flows to an aeration basin. A portion of the secondary process flow can be diverted to the reclamation facilities for tertiary treatment with gravity filters. The remaining secondary effluent flows to the head of the chlorine contact channel where sodium hypochlorite is injected to kill bacteria in the effluent. Prior to discharge into the ocean, sodium bisulfite is added for dechlorination, thus completing the disinfection process.

4. **Biosolids Management.** Settleable solids and floatable materials from the primary clarifiers are treated in three heated anaerobic sludge digesters for a minimum of 15 days. Sludge from the digesters then flows to one of two stabilization basins. Stabilized sludge is dredged from the bottom of the basins and is dewatered by two new screw presses. The digested supernatant from the three anaerobic digesters can also be diverted from the stabilization basins directly to the screw presses for dewatering.
5. **Recycled Water Production.** Using coagulation, flocculation, filtration, and chlorination processes, up to 3.3 MGD (or 11,400 m<sup>3</sup>/day) of its municipal wastewater is tertiary-treated to meet Title 22 Water Recycling Criteria. Since 1991 and in accordance with Waste Discharge Requirements Order No. 91-03, the Discharger provides recycled wastewater to the Goleta Water District for landscape irrigation and incidental uses, such as dust control and compaction at construction sites.

**B. Discharge Points and Receiving Waters**

Effluent is discharged to the Pacific Ocean through an outfall pipe located 5,800 feet from shore that terminates at a depth of approximately 92 feet below sea level. The diffuser utilizes 36 four-inch diameter ports to achieve a minimum initial dilution of 122 parts seawater for every part effluent (122:1).

**C. Summary of Existing Requirements and Self-Monitoring Report (SMR) Data**

Effluent limitations contained in the existing Order for discharges from Discharge Point No. 001 (Monitoring Location EFF-001) and representative monitoring data from the term of the previous Order are as follows:

**Table F-2. Historic Effluent Limitations and Monitoring Data**

Parameter	Units	Effluent Limitation			Monitoring Data (From September 2010 – To June 2015)		
		Average Monthly	Average Weekly	Instantaneous Maximum	Highest Average Monthly Discharge	Highest Average Weekly Discharge	Highest Instant Max Discharge
Biochemical Oxygen Demand 5-day @ 20°C (BOD <sub>5</sub> ) <sup>[1]</sup>	mg/L	98	---	150	91	---	149
	lbs/day <sup>[1]</sup>	6,240	---	9,560	225	---	796
Total Suspended Solids (TSS) <sup>[1]</sup>	mg/L	63	---	100	54	---	95
	lbs/day <sup>[1]</sup>	4,010	---	6,370	345	---	828
Oil and Grease	mg/L	25	40	75	21	28	30
	lbs/day <sup>[1]</sup>	1,590	2,550	4,780	NR	NR	NR
Settleable Solids	mL/L/hr	1.0	1.5	3.0	0.45	0.56	1.6
Turbidity	NTU	75	100	225	54	61	85
pH	standard units	6.0 – 9.0 at all times			6.1 – 7.8		

NR – Not Reported

<sup>[1]</sup> Mass emission rates for the previous Order were based on the annual monthly average flow of 7.64 MGD.

**Table F-3. Historic Effluent Limitations and Monitoring Data, Protection of Marine Aquatic Life**

Parameter	Units	Effluent Limitation			Monitoring Data From From September 2010 – June 2015		
		6- Month Median	Maximum Daily	Instant Max	Highest 6- Month Median	Highest Maximum Daily	Highest Instant Max
Arsenic	µg/L	618	3,570	9,474	1.66	21	21
Cadmium	µg/L	123	492	1,230	0.20	0.5	0.5
Chromium VI	µg/L	246	987	2,460	3	8	8
Copper	µg/L	125	1,232	3,446	35	120	120
Lead	µg/L	246	987	2,460	0.73	13	13
Mercury	µg/L	4.9	20	49	30	30	30
Nickel	µg/L	615	2,460	6,150	8.7	20	20
Selenium	µg/L	1,845	7,348	18,450	NR	997	997
Silver	µg/L	67	325	841	0.509	1.0	1.0
Zinc	µg/L	1,484	8,864	23,624	56	100	100
Cyanide	µg/L	123	492	1,230	NR	1.86 J	1.86 J
Total Chlorine Residual	µg/L	246	984	7,380	280	300	300
Ammonia	mg/L as N	73.8	295.2	738	48	58	58
Acute Toxicity	TUa	---	4.0	---	---	3.4	---
Chronic Toxicity	TUc	---	123	---	---	18	---
Phenolic Compounds (non-chlorinated)	µg/L	3,690	14,760	36,900	NR	<0.00004	<0.00004
Phenolic Compounds (chlorinated)	µg/L	123	492	1,230	NR	<1.0	<1.0
Endosulfan	µg/L	1.107	2.214	3.321	NR	<0.01	<0.01
Endrin	µg/L	0.246	0.492	0.738	NR	<0.041	<0.041
HCH	µg/L	0.492	0.984	1.476	NR	NR	NR
Radioactivity	pCi/L	[1]			NR	26	26

NR = Not Reported

[1]. Not to exceed limits specified in Title 17, Division 1, Chapter 5, Subchapter 4, Group 3, Article 3, Section 30253 of the California Code of Regulations. Reference to Section 30253 is prospective, including future changes to any incorporated provisions of federal law, as the changes.

**Table F-4. Historic Effluent Limitations and Monitoring Data for Non-Carcinogens and Carcinogens**

Parameter	Units	Effluent Limitation	Monitoring Data From September 2010 – June 2015
		Average Monthly	Highest Average Monthly Discharge
<b>Non-carcinogens</b>			
Acrolein	µg/L	27,060	<4.1
Antimony	µg/L	147,600	2.0
Bis(2-chloroethoxy) methane	µg/L	541.2	<0.54

Parameter	Units	Effluent Limitation	Monitoring Data From September 2010 – June 2015
		Average Monthly	Highest Average Monthly Discharge
Bis(2-chloroisopropyl) ether	µg/L	147,600	<0.41
Chlorobenzene	µg/L	70,110	1.2
Chromium (III)	µg/L	2.34E+07	1.0
Di-n-butyl phthalate	µg/L	430,500	<0.35
Dichlorobenzenes	µg/L	627,300	<0.054
Diethyl phthalate	µg/L	4.06E+06	1.0
Dimethyl phthalate	µg/L	100,860,000	<0.31
4,6-dinitro-2-methylphenol	µg/L	27,060	<0.43
2,4-dinitrophenol	µg/L	492	<0.79
Ethylbenzene	µg/L	504,300	<0.045
Fluoranthene	µg/L	1,845	0.33
Hexachlorocyclopentadiene	µg/L	7,134	<0.24
Nitrobenzene	µg/L	603	<0.47
Thallium	µg/L	246	<0.000014
Toluene	µg/L	1.05E+07	1.28
Tributyltin	µg/L	0.172	0.1
1,1,1-trichloroethane	µg/L	6.64E+07	<0.082
<b>Carcinogens</b>			
Acrylonitrile	µg/L	12.3	<1.2
Aldrin	µg/L	0.0027	<0.013
Benzene	µg/L	725.7	<0.04
Benzidine	µg/L	0.0085	<1.8
Beryllium	µg/L	4.059	<0.000043
Bis(2-chloroethyl) ether	µg/L	5.535	<0.51
Bis(2-ethylhexyl) phthalate	µg/L	430.5	7.0
Carbon tetrachloride	µg/L	110.7	<0.025
Chlordane	µg/L	0.0028	<0.16
Chlorodibromomethane	µg/L	1,057	30.1
Chloroform	µg/L	15,990	71.3
DDT	µg/L	0.02091	<0.01
1,4-dichlorobenzene	µg/L	2,214	<0.054
3,3-dichlorobenzidine	µg/L	0.9963	<0.43
1,2-dichloroethane	µg/L	3,444	<0.036
1,1-dichloroethylene	µg/L	110.7	<0.036
Dichlorobromomethane	µg/L	762.6	51.2
Dichloromethane	µg/L	55,350	<0.052
1,3-dichloropropene	µg/L	1,094	<0.061
Dieldrin	µg/L	0.00492	<0.01
2,4-dinitrotoluene	µg/L	319.8	<0.49
1,2-diphenylhydrazine	µg/L	19.68	<0.47
Halomethanes	µg/L	15,990	154.7
Heptachlor	µg/L	0.00615	<0.0065

Parameter	Units	Effluent Limitation	Monitoring Data From September 2010 – June 2015
		Average Monthly	Highest Average Monthly Discharge
Heptachlor epoxide	µg/L	0.00246	<0.011
Hexachlorobenzene	µg/L	0.02583	<0.39
Hexachlorobutadiene	µg/L	1,722	<0.37
Hexachloroethane	µg/L	307.5	<0.38
Isophorone	µg/L	89,790	<0.41
N-nitrosodimethylamine	µg/L	897.9	<0.47
N-nitrosodi-n-propylamine	µg/L	46.74	<0.53
N-nitrosodiphenylamine	µg/L	307.5	<0.50
PAHs	µg/L	1.0824	<0.02
PCBs	µg/L	0.0023	<0.69
TCDD equivalents	µg/L	0.48	<0.952
1,1,2,2-tetrachloroethane	µg/L	282.9	NR
Tetrachloroethylene	µg/L	246	<0.099
Toxaphene	µg/L	0.026	<0.18
Trichloroethylene	µg/L	3,321	<0.11
1,1,2-trichloroethane	µg/L	1,156	<0.035
2,4,6-trichlorophenol	µg/L	36.67	<0.47
Vinyl chloride	µg/L	4,428	<0.15

**D. Compliance Summary**

The Discharger did not have any reported violations during the term of the previous Order.

**E. Planned Changes**

The Facility does not plan to implement any further changes during the upcoming permit term.

**III. APPLICABLE PLANS, POLICIES, AND REGULATIONS**

The requirements contained in this Order are based on the requirements and authorities described in this section.

**A. Legal Authorities**

This Order serves as waste discharge requirements (WDRs) pursuant to article 4, chapter 4, division 7 of the California Water Code (commencing with section 13260). This Order is also issued pursuant to section 402 of the federal Clean Water Act (CWA) and implementing regulations adopted by the U.S. EPA and chapter 5.5, division 7 of the Water Code (commencing with section 13370). It shall serve as an NPDES permit for point source discharges from this facility to surface waters. California Environmental Quality Act (CEQA)

Under Water Code section 13389, this action to adopt an NPDES permit is exempt from the provisions of Chapter 3 of CEQA, (commencing with section 21100) of Division 13 of the Public Resources Code.



**B. State and Federal Laws, Regulations, Policies, and Plans**

- 1. Water Quality Control Plan.** The Central Coast Water Board has adopted the *Water Quality Control Plan for the Central Coastal Basin* (hereinafter Basin Plan), which designates beneficial uses, establishes water quality objectives, and contains implementation programs and policies to achieve those objectives for receiving waters within the Region. To address ocean waters, the Basin Plan incorporates by reference the *Water Quality Plan for Ocean Waters of California* (the Ocean Plan). Beneficial uses applicable to the Pacific Ocean are as follows:

**Table F-5. Basin Plan Beneficial Uses**

Discharge Point	Receiving Water Name	Beneficial Use(s)
001	Pacific Ocean	Water Contact (REC-1) Non-Contact Recreation (REC-2) Industrial Supply (IND) Navigation (NAV) Marine Habitat (MAR) Shellfish Harvesting (SHELL) Commercial and Sport Fishing (COMM) Rare, Threatened, or Endangered Species (RARE) Wildlife Habitat (WILD)

**California Ocean Plan.** The State Water Board adopted the Water Quality Control Plan for Ocean Waters of California, California Ocean Plan (Ocean Plan) in 1972 and amended it in 1978, 1983, 1988, 1990, 1997, 2000, 2005, 2009, 2012 and 2015. The State Water Board adopted the latest amendment on May 6, 2015, and it became effective on April 7, 2016. The Ocean Plan is applicable, in its entirety, to point source discharges to the ocean. The Ocean Plan identifies beneficial uses of ocean waters of the state to be protected as summarized below:

**Table F-6. Ocean Plan Beneficial Uses**

Discharge Point	Receiving Water	Beneficial Uses
001	Pacific Ocean	Industrial water supply Water Contact and non-contact recreation, including aesthetic enjoyment Navigation Commercial and sport fishing Mariculture Preservation and enhancement of designated areas of special biological significance (ASBS) Rare and endangered species Marine habitat Fish migration Fish spawning and shellfish harvesting

In order to protect the beneficial uses, the Ocean Plan establishes water quality objectives and a program of implementation. Requirements of this Order implement the Ocean Plan.

2. **Antidegradation Policy.** Federal regulation 40 C.F.R. section 131.12 requires that state water quality standards include an antidegradation policy consistent with the federal policy. The State Water Board established California's antidegradation policy in State Water Board Resolution No. 68-16. Resolution No. 68-16 is deemed to incorporate the federal antidegradation policy where the federal policy applies under federal law. Resolution No. 68-16 requires that existing water quality be maintained unless degradation is justified based on specific findings. The Central Coast Water Board's Basin Plan implements, and incorporates by reference, both the state and federal antidegradation policies. The permitted discharge must be consistent with the antidegradation provision of section 131.12 and State Water Board Resolution 68-16.
3. **Anti-Backsliding Requirements.** Sections 402(o) and 303(d)(4) of the CWA and federal regulations at 40 C.F.R. section 122.44(l) restrict backsliding in NPDES permits. These anti-backsliding provisions require that effluent limitations in a reissued permit must be as stringent as those in the previous permit, with some exceptions in which limitations may be relaxed.
4. **Endangered Species Act Requirements.** This Order does not authorize any act that results in the taking of a threatened or endangered species or any act that is now prohibited, or becomes prohibited in the future, under either the California Endangered Species Act (Fish and Game Code, §§ 2050 to 2097) or the Federal Endangered Species Act (16 U.S.C.A. §§ 1531 to 1544). This Order requires compliance with effluent limits, receiving water limits, and other requirements to protect the beneficial uses of waters of the state, including protecting rare and endangered species. The Discharger is responsible for meeting all requirements of the applicable Endangered Species Act.

#### C. Impaired Water Bodies on CWA 303(d) List

CWA section 303(d) requires states to identify specific water bodies where water quality standards are not expected to be met after implementation of technology-based effluent limitations on point sources. For all 303(d) listed water bodies and pollutants, the Central Coast Water Board must develop and implement Total Maximum Daily Loads (TMDLs) that will specify Waste Load Allocations (WLAs) for point sources and Load Allocations (LAs) for non-point sources.

The USEPA approved the State's 2012 303(d) list of impaired water bodies on July 30, 2015. The 2012 303(d) list identifies the Pacific Ocean at Goleta Beach as impaired for total coliform. A TMDL is needed for total coliform, but there is no TMDL currently in place. The outfall for this discharge is located approximately 5,800 feet offshore of Goleta Beach. This Order includes effluent limitations for total coliform bacteria.

#### D. Other Plans, Policies and Regulations

1. **Storm Water Management.** For the control of storm water discharged from the site of the wastewater treatment and disposal facilities, the Order requires, if applicable, the Discharger to seek authorization to discharge under and meet the requirements of the State Water Resources Control Board's Water Quality Order 2014-0057-DWQ, NPDES General Permit No. CAS000001, *Waste Discharge Requirements for Discharges of Storm Water Associated with Industrial Activities Excluding Construction Activities*.
2. **Sanitary Sewer System Requirements.** The State Water Board has adopted a Statewide general permit for the regulation of the operation, maintenance, and monitoring of collection systems. This Order requires coverage by and compliance with

applicable provisions of General Waste Discharge Requirements for Sanitary Sewer Systems (State Water Board Order No. 2006-0003-DWQ). This General Permit, adopted on May 2, 2006, is applicable to all "federal and state agencies, municipalities, counties, districts, and other public entities that own or operate sanitary sewer systems greater than one mile in length that collect and/or convey untreated or partially treated wastewater to a publicly owned treatment facility in the State of California." The purpose of the General Permit is to promote the proper and efficient management, operation, and maintenance of sanitary sewer systems and to minimize the occurrences and impacts of sanitary sewer overflows. The Discharger is enrolled under the General Permit.

#### IV. RATIONALE FOR EFFLUENT LIMITATIONS AND DISCHARGE SPECIFICATIONS

The CWA requires point source dischargers to control the amount of conventional, non-conventional, and toxic pollutants that are discharged into the waters of the United States. The control of pollutants discharged is established through effluent limitations and other requirements in NPDES permits. There are two principal bases for effluent limitations in the Code of Federal Regulations: 40 C.F.R. section 122.44(a) requires that permits include applicable technology-based limitations and standards; and 40 C.F.R. section 122.44(d) requires that permits include water quality-based effluent limitations to attain and maintain applicable numeric and narrative water quality criteria to protect the beneficial uses of the receiving water.

##### A. Discharge Prohibitions

- 1. Discharge Prohibition III.A and III.B.** (Discharge of treated wastewater at a location or in a manner different from that described in this Order is prohibited; Discharge of waste not specifically regulated by this Order is prohibited): These prohibitions are similar to the previous Order and is based on 40 CFR 122.21(a), duty to apply, and CWC Section 13260, which requires filing a ROWD before discharges can occur. Discharges not described in the ROWD, and subsequently in this Order, are prohibited. This prohibition is retained from the previous Order.
- 2. Discharge Prohibition III.C:** (The average dry weather monthly rate of discharge to the Pacific Ocean shall not exceed 7.64 MGD). Consistent with State and federal antibacksliding regulations, this flow limitation is retained from the previous permit.
- 3. Discharge Prohibition III.D.** (Discharges of radiological chemical, or biological warfare agent or high level radioactive waste to the Ocean is prohibited). This prohibition has been retained from the previous Order and is consistent with Section III.I.1. of the Ocean Plan.
- 4. Discharge Prohibition III.E.** (Discharge of sludge and sludge digester supernatant to the Ocean is Prohibited). This prohibition has been retained from the previous Order and is consistent with Section III.I.3. of the Ocean Plan.
- 5. Discharge Prohibition III.F.** (Overflows and bypasses prohibited). The discharge of untreated or partially treated wastewater from the Discharger's collection, treatment, or disposal facilities represents an unauthorized bypass pursuant to 40 CFR 122.41(m) or an unauthorized discharge, which poses a threat to human health and/or aquatic life, and therefore, is explicitly prohibited by the Order. This provision has also been retained from the previous Order and is consistent with Section III.I.4. of the Ocean Plan.

- 6. **Discharge Prohibition III.G.** (Materials and substances that are prohibited). This prohibition is based on the requirements of the Ocean Plan.

**B. Technology-Based Effluent Limitations**

**1. Scope and Authority**

Section 301(b) of the CWA and implementing USEPA permit regulations at 40 C.F.R. 122.44 (a) require that permits include applicable technology-based limitations and standards, at a minimum, and any more stringent effluent limitations necessary to meet applicable water quality standards. Where the USEPA has not yet developed technology based standards for a particular industry or a particular pollutant, CWA 402 (a) (1) and USEPA regulations at 40 CFR 125.3 authorize the use of Best Professional Judgment (BPJ) to derive technology-based effluent limitations on a case-by-case basis, in accordance with 40 C.F.R. 125, specifically, 40 C.F.R. 125.3.

Under CWA section 301(h), the previous Order conditionally waived the requirement for municipal wastewater treatment plants to comply with secondary standards before discharging wastewater to the ocean. As of December 2013, the Facility has upgraded to achieve full secondary treatment, thus the 301(h) waiver is no longer applicable. Therefore, this Order includes limitations based on the minimum level of effluent quality attainable by secondary treatment, as established at 40 CFR 133. The Secondary Treatment Regulation includes the following limitations.

**Table F-7. Secondary Treatment Requirements**

Parameter	Units	30-Day Average	7-Day Average
BOD <sub>5</sub> <sup>[1] [2]</sup>	mg/L	30	45
TSS <sup>[1]</sup>	mg/L	30	45
pH	standard units	6.0 – 9.0	

<sup>[1]</sup> The 30-day average percent removal for BOD<sub>5</sub> and TSS shall not be less than 85 percent.

<sup>[2]</sup> At the option of the permitting authority, effluent limitations for CBOD<sub>5</sub> may be substituted for those limitations specified for BOD<sub>5</sub>.

**2. Applicable Technology-Based Effluent Limitations**

Title 40 CFR 122.45(f)(1) requires effluent limitations be expressed in terms of mass, with some exceptions, and 40 CFR 122.45(f)(2) allows pollutants that are limited in terms of mass to additionally be limited in terms of other units of measurement. This Order includes effluent limitations expressed in terms of mass and concentration. In addition, pursuant to the exceptions to mass limitations provided in 40 CFR 122.45(f)(1), some effluent limitations are not expressed in terms of mass, such as pH and temperature, and when the applicable standards are expressed in terms of concentration and mass limitations are not necessary to protect the beneficial uses of the receiving waters.

- a. **BOD<sub>5</sub> and TSS.** Federal Regulations, 40 CFR 133, establish the minimum weekly and monthly average level of effluent quality attainable by secondary treatment for BOD<sub>5</sub> and TSS. Effluent limitations for BOD<sub>5</sub> and TSS have thus been established in this Order based on these standards.

Additionally, 40 CFR 133.102, in describing the minimum level of effluent quality attainable by secondary treatment, states that the 30-day average percent removal

shall not be less than 85 percent. This Order contains a limitation requiring an average of 85 percent removal of BOD<sub>5</sub> and TSS over each calendar month.

- b. **pH.** Federal Regulations, 40 CFR 133, establishes technology-based effluent limitations for pH. The secondary treatment standards require the pH of the effluent to be no lower than 6.0 and no greater than 9.0 standard units. This pH range is also consistent with the Ocean Plan Table 2 effluent limitations.
- c. **Settleable Solids.** The Ocean Plan Table 2 establishes the minimum weekly, monthly, and maximum average of effluent quality attainable by secondary treatment for settleable solids. Effluent limitations for settleable solids have been established in this Order based on these requirements.
- d. **Oil and Grease.** The Ocean Plan Table 2 establishes the minimum weekly, monthly, and maximum average of effluent quality attainable by secondary treatment for oil and grease. Effluent limitations for oil and grease have been established in this Order based on these requirements.
- e. **Turbidity.** The Ocean Plan Table 2 establishes the minimum weekly, monthly, and maximum average of effluent quality attainable by secondary treatment for turbidity. Effluent limitations for turbidity have been established in this Order based on these requirements.

The following table summarizes technology-based effluent limitations established by the Order.

**Table F-8. Technology-Based Effluent Limitations**

Parameter	Units	Effluent Limitations		
		Average Monthly	Average Weekly	Instantaneous Maximum
Biochemical Oxygen Demand 5-day @ 20°C (BOD <sub>5</sub> ) <sup>[1]</sup>	mg/L	30	45	---
	lbs/day <sup>[2]</sup>	1,912	2,867	---
Total Suspended Solids (TSS) <sup>[1]</sup>	mg/L	30	45	---
	lbs/day <sup>[2]</sup>	1,912	2,867	---
Settleable Solids	ml/L/hr	1.0	1.5	3.0
Turbidity	NTU	75	100	225
Oil and Grease	mg/L	25	40	75
	lbs/day <sup>[2]</sup>	1,590	2,549	4,779
pH	standard units	6.0 – 9.0 <sup>[3]</sup>		

<sup>[1]</sup> The 30-day average percent removal for BOD<sub>5</sub> and TSS shall not be less than 85 percent.

<sup>[2]</sup> Mass-based effluent limitations were calculated using the following formula:  
 lbs/day = pollutant concentration (mg/L) \* permitted flow (7.64 MGD) \* conversion factor (8.34)

<sup>[3]</sup> Applied as an instantaneous minimum and maximum.

## **C. Water Quality-Based Effluent Limitations**

### **1. Scope and Authority**

CWA Section 301(b) and 40 C.F.R. section 122.44(d) require that permits include limitations more stringent than applicable federal technology-based requirements where necessary to achieve applicable water quality standards.

Section 122.44(d)(1)(i) of 40 C.F.R. requires that permits include effluent limitations for all pollutants that are or may be discharged at levels that have the reasonable potential to cause or contribute to an exceedance of a water quality standard, including numeric and narrative objectives within a standard. Where reasonable potential has been established for a pollutant, but there is no numeric criterion or objective for the pollutant, water quality-based effluent limitations (WQBELs) must be established using: (1) USEPA criteria guidance under CWA section 304(a), supplemented where necessary by other relevant information; (2) an indicator parameter for the pollutant of concern; or (3) a calculated numeric water quality criterion, such as a proposed state criterion or policy interpreting the state's narrative criterion, supplemented with other relevant information, as provided in section 122.44(d)(1)(vi).

The process for determining reasonable potential and calculating WQBELs when necessary is intended to protect the designated uses of the receiving water as specified in the Basin Plan, and achieve applicable water quality objectives and criteria that are contained in other state plans and policies, or any applicable water quality criteria contained in the Ocean Plan.

### **2. Applicable Beneficial Uses and Water Quality Criteria and Objectives**

Beneficial uses for ocean waters of the Central Coast Region are established by the Basin Plan and Ocean Plan and are described in section III.C of this Fact Sheet.

Water quality criteria applicable to ocean waters of the Region are established by the Ocean Plan, which includes WQOs for bacterial characteristics, physical characteristics, chemical characteristics, biological characteristics, and radioactivity. The WQOs from the Ocean Plan are incorporated as receiving water limitations in this Order. In addition, Table 1 of the Ocean Plan contains numeric WQOs for 83 toxic pollutants for the protection of marine aquatic life and human health. Pursuant to NPDES regulations at 40 CFR 122.44(d)(1), and in accordance with procedures established by the Ocean Plan (2015), the central Coast Water Board has performed a reasonable potential analysis (RPA) to determine the need for effluent limitations for Table 1 toxic pollutants.

### **3. Determining the Need for WQBELs**

Procedures for performing an RPA for ocean dischargers are described in section III.C and Appendix VI of the Ocean Plan. The procedure is a statistical method that projects an effluent data set while taking into account the averaging period of WQOs, the long term variability of pollutants in the effluent, limitations associated with sparse data sets, and uncertainty associated with censored data sets. The procedure assumes a lognormal distribution of the effluent data set, and compares the 95<sup>th</sup> percentile concentration at 95 percent confidence of each Table 1 pollutant, accounting for dilution, to the applicable water quality criterion. The RPA results in one of the three following endpoints:

- Endpoint 1 - There is “reasonable potential.” An effluent limitation must be developed for the pollutant. Effluent monitoring for the pollutant, consistent with the monitoring frequency in Appendix III (Ocean Plan), is required.
- Endpoint 2 - There is no “reasonable potential.” An effluent limitation is not required for the pollutant. Appendix III (Ocean Plan) effluent monitoring is not required for the pollutant; the Central Coast Board, however, may require occasional monitoring for the pollutant or for whole effluent toxicity as appropriate.
- Endpoint 3 - The RPA is inconclusive. Monitoring for the pollutant or whole effluent toxicity testing, consistent with the monitoring frequency in Appendix III, is required. An existing effluent limitation for the pollutant shall remain in the permit, otherwise the permit shall include a reopener clause to allow for subsequent modification of the permit to include an effluent limitation if monitoring establishes that the discharge causes, has the reasonable potential to cause, or contribute to an excursion above a Table 1 water quality objective.

The State Water Board has developed a reasonable potential calculator, which is available at:

[http://www.waterboards.ca.gov/water\\_issues/programs/ocean/docs/trirev/stakeholder050505/rpcalc22\\_setup.zip](http://www.waterboards.ca.gov/water_issues/programs/ocean/docs/trirev/stakeholder050505/rpcalc22_setup.zip)

The calculator (RPcalc 2.2) was used in the development of this Order and considers several pathways in the determination of reasonable potential.

**a. First Path**

If available information about the receiving water or the discharge supports a finding of reasonable potential without analysis of effluent data, the Central Coast Water Board may decide that WQBELs are necessary after a review of such information. Such information may include: the facility or discharge type, solids loading, lack of dilution, history of compliance problems, potential toxic effects, fish tissue data, 303(d) status of the receiving water, the presence of threatened or endangered species or their critical habitat, or other information.

**b. Second Path**

If any pollutant concentration, adjusted to account for dilution, is greater than the most stringent applicable WQO, there is reasonable potential for that pollutant.

**c. Third Path**

If the effluent data contains three or more detected and quantified values (i.e., values that are at or above the minimum level (ML)), and all values in the data set are at or above the ML, a parametric RPA is conducted to project the range of possible effluent values. The 95<sup>th</sup> percentile concentration is determined at 95 percent confidence for each pollutant, and compared to the most stringent

applicable water quality objective to determine reasonable potential. A parametric analysis assumes that the range of possible effluent values is distributed log-normally. If the 95<sup>th</sup> percentile value is greater than the most stringent applicable water quality objective, there is reasonable potential for that pollutant.

**d. Fourth Path**

If the effluent data contains three or more detected and quantified values (i.e., values that are at or above the ML), but at least one value in the data set is less than the ML, a parametric RPA is conducted according to the following steps:

- i. If the number of censored values (those expressed as a “less than” value) account for less than 80 percent of the total number of effluent values, calculate the ML (the mean of the natural log of transformed data) and S<sub>L</sub> (the standard deviation of the natural log of transformed data) and conduct a parametric RPA, as described above for the Third Path.
- ii. If the total number of censored values account for 80 percent of the total number of effluent values, conduct a non-parametric RPA, as described below for the Fifth Path. (A non-parametric analysis becomes necessary when the effluent data is limited, and no assumptions can be made regarding its possible distribution).

**e. Fifth Path**

A non-parametric RPA is conducted when the effluent data set contains less than three detected and quantified values, or when the effluent data set contains three or more detected and quantified values but the number of censored values accounts for 80 percent or more of the total of effluent values. A non-parametric analysis is conducted by ordering the data, comparing each result to the applicable WQO, and accounting for ties. The sample number is reduced by one for each tie, when the dilution-adjusted method detection limit (MDL) is greater than the water quality objective. If the adjusted sample number, after accounting for ties, is greater than 15, the pollutant has no reasonable potential to exceed the WQO. If the sample number is 15 or less, the RPA is inconclusive, monitoring is required, and any existing effluent limits in the expiring permit are retained.

In this case, a RPA was conducted using effluent monitoring data from September 2010 to June 2015. The implementation provisions for Table 1 in Section III.C of the Ocean Plan specify that the minimum initial dilution is the lowest average initial dilution within any single month of the year. Dilution estimates shall be based on observed waste flow characteristics, observed receiving water density structure, and the assumption that no currents of sufficient strength to influence the initial dilution process flow across the discharge structure. Order No. R3-2010-0012 determined the minimum initial dilution factor (D<sub>m</sub>) for the discharge to be 122 to 1 (seawater to effluent). This D<sub>m</sub> of 122:1 will be retained from the current Order and applied to the WQBELs established herein. If the actual dilution ratio is found to be different, then the ratio will be recalculated and this Order may be reopened when and as appropriate.

A summary of the RPA results is provided below. As shown in the table, due to insufficient data, the RPA frequently leads to Endpoint 3 meaning that the RPA is



inconclusive. In these circumstances, the Ocean Plan requires that existing effluent limitations for those pollutants (for which the RPA is inconclusive) remain in the reissued permit. When the RPA lead to Endpoint 2 meaning there is no reasonable potential for that pollutant, the limit has been removed for this permit term. When using all available data for the past permit term, the RPA did show "reasonable potential," indicated by a result of Endpoint 1, for mercury and dichlorobromomethane. Because the Facility significantly upgraded to full secondary treatment in December 2013, the RPA was re-run for these two parameters using data from the time of secondary treatment implementation to present which is representative of current effluent quality. This resulted in Endpoint 2 for mercury and Endpoint 3 in dichlorobromomethane due to lack of data. This conclusion is representative of effluent characteristics going forward, and the Facility shall continue to monitor for all Ocean Plan Table 1 pollutants.

**Table F-9. RPA Results**

Parameter	Units	N <sup>[1]</sup>	MEC <sup>[2],[3]</sup>	Most Stringent Criteria	Background	RPA Endpoint <sup>[4]</sup>
Arsenic	µg/L	58	21	8 <sup>[5]</sup>	3 <sup>[6]</sup>	2
Cadmium	µg/L	58	0.5	1 <sup>[5]</sup>	0	2
Chromium, Hexavalent	µg/L	59	8	2 <sup>[5]</sup>	0	2
Copper	µg/L	58	120	3 <sup>[5]</sup>	2 <sup>[6]</sup>	2
Lead	µg/L	58	13.4	2 <sup>[5]</sup>	0	2
Mercury	µg/L	6	0.08	0.04 <sup>[5]</sup>	0.0005 <sup>[6]</sup>	2
Nickel	µg/L	58	20	5 <sup>[5]</sup>	0	2
Selenium	µg/L	5	997	15 <sup>[5]</sup>	0	3
Silver	µg/L	58	1	0.7 <sup>[5]</sup>	0.16 <sup>[6]</sup>	2
Zinc	µg/L	58	100	20 <sup>[5]</sup>	8 <sup>[6]</sup>	2
Cyanide	µg/L	5	<0.0000011	1 <sup>[5]</sup>	0	3
Total Residual Chlorine	µg/L	1,764	0.3	2 <sup>[5]</sup>	0	2
Ammonia	µg/L as N	57	58.5	600 <sup>[5]</sup>	0	2
Acute Toxicity	TUa	19	3.36	0.3 <sup>[7]</sup>	0	2
Chronic Toxicity	TUc	25	17.9	1 <sup>[7]</sup>	0	2
Phenolic Compounds <sup>[8]</sup>	µg/L	5	<0.00004	30 <sup>[5]</sup>	0	3
Chlorinated Phenolics <sup>[9]</sup>	µg/L	5	<1	1 <sup>[5]</sup>	0	3
Endosulfan <sup>[10]</sup>	µg/L	5	<0.01	0.009 <sup>[5]</sup>	0	3
Endrin	µg/L	5	<0.041	0.002 <sup>[5]</sup>	0	3
HCH <sup>[11]</sup>	µg/L	NR	NR	0.004 <sup>[5]</sup>	0	3
Radioactivity <sup>[12]</sup>	pCi/L	-----	-----	<sup>[12]</sup>	0	-----
Acrolein	µg/L	5	<4.1	220 <sup>[13]</sup>	0	3
Antimony	µg/L	5	2	1,200 <sup>[13]</sup>	0	2
Bis(2-chloroethoxy) methane	µg/L	5	<0.54	4.4 <sup>[13]</sup>	0	3
Bis(2-chloroisopropyl) ether	µg/L	5	<0.41	1,200 <sup>[13]</sup>	0	3
Chlorobenzene	µg/L	5	1.2	570 <sup>[13]</sup>	0	3
Chromium (III)	µg/L	4	1	190,000 <sup>[13]</sup>	0	2
Di-n-butyl phthalate	µg/L	5	<0.35	3,500 <sup>[13]</sup>	0	3
Dichlorobenzenes <sup>[14]</sup>	µg/L	5	<0.054	5,100 <sup>[13]</sup>	0	3
Diethyl phthalate	µg/L	5	1	33,000 <sup>[13]</sup>	0	3

Parameter	Units	N <sup>[1]</sup>	MEC <sup>[2],[3]</sup>	Most Stringent Criteria	Background	RPA Endpoint <sup>[4]</sup>
Dimethyl phthalate	µg/L	5	<0.31	820,000 <sup>[13]</sup>	0	3
4,6-dinitro-2-methylphenol	µg/L	10	<0.43	220 <sup>[13]</sup>	0	3
2,4-dinitrophenol	µg/L	5	<0.79	4.0 <sup>[13]</sup>	0	3
Ethylbenzene	µg/L	5	<0.045	4,100 <sup>[13]</sup>	0	3
Fluoranthene	µg/L	5	0.33	15 <sup>[13]</sup>	0	3
Hexachlorocyclopentadiene	µg/L	5	<0.24	58 <sup>[13]</sup>	0	3
Nitrobenzene	µg/L	5	<0.47	4.9 <sup>[13]</sup>	0	3
Thallium	µg/L	5	<0.014	2 <sup>[13]</sup>	0	3
Toluene	µg/L	5	1.28	85,000 <sup>[13]</sup>	0	3
Tributyltin	µg/L	5	0.1	0.0014 <sup>[13]</sup>	0	3
1,1,1-trichloroethane	µg/L	5	<0.082	540,000 <sup>[13]</sup>	0	3
Acrylonitrile	µg/L	5	<1.2	0.10 <sup>[13]</sup>	0	3
Aldrin	µg/L	5	<0.013	0.000022 <sup>[13]</sup>	0	3
Benzene	µg/L	5	<0.04	5.9 <sup>[13]</sup>	0	3
Benzidine	µg/L	5	<1.8	0.000069 <sup>[13]</sup>	0	3
Beryllium	µg/L	5	<0.043	0.033 <sup>[13]</sup>	0	3
Bis(2-chloroethyl) ether	µg/L	5	<0.51	0.045 <sup>[13]</sup>	0	3
Bis(2-ethylhexyl) phthalate	µg/L	5	7	3.5 <sup>[13]</sup>	0	2
Carbon tetrachloride	µg/L	5	<0.025	0.90 <sup>[13]</sup>	0	3
Chlordane <sup>[15]</sup>	µg/L	5	<0.16	0.000023 <sup>[13]</sup>	0	3
Chlorodibromomethane	µg/L	5	30.1	8.6 <sup>[13]</sup>	0	3
Chloroform	µg/L	5	71.3	130 <sup>[13]</sup>	0	2
DDT <sup>[16]</sup>	µg/L	5	<0.01	0.00017 <sup>[13]</sup>	0	3
1,4-dichlorobenzene	µg/L	5	<0.054	18 <sup>[13]</sup>	0	3
3,3'-dichlorobenzidene	µg/L	5	<0.43	0.0081 <sup>[13]</sup>	0	3
1,2-dichloroethane	µg/L	5	<0.036	28 <sup>[13]</sup>	0	3
1,1-dichloroethylene	µg/L	5	<0.036	0.9 <sup>[13]</sup>	0	3
Dichlorobromomethane	µg/L	5	51.2	6.2 <sup>[13]</sup>	0	3
Dichloromethane	µg/L	1	<0.052	450 <sup>[13]</sup>	0	3
1,3-dichloropropene	µg/L	6	<0.061	8.9 <sup>[13]</sup>	0	3
Dieldrin	µg/L	5	<0.01	0.00004 <sup>[13]</sup>	0	3
2,4-dinitrotoluene	µg/L	5	<0.49	2.6 <sup>[13]</sup>	0	3
1,2-diphenylhydrazine	µg/L	5	<0.47	0.16 <sup>[13]</sup>	0	3
Halomethanes <sup>[17]</sup>	µg/L	5	154.7	130 <sup>[13]</sup>	0	2
Heptachlor	µg/L	5	<0.0065	0.00005 <sup>[13]</sup>	0	3
Heptachlor epoxide	µg/L	5	<0.011	0.00002 <sup>[13]</sup>	0	3
Hexachlorobenzene	µg/L	5	<0.39	0.00021 <sup>[13]</sup>	0	3
Hexachlorobutadiene	µg/L	5	<0.37	14 <sup>[13]</sup>	0	3
Hexachloroethane	µg/L	5	<0.38	2.5 <sup>[13]</sup>	0	3
Isophorone	µg/L	5	<0.41	730 <sup>[13]</sup>	0	3
N-nitrosodimethylamine	µg/L	5	<0.47	7.3 <sup>[13]</sup>	0	3

Parameter	Units	N <sup>[1]</sup>	MEC <sup>[2],[3]</sup>	Most Stringent Criteria	Background	RPA Endpoint <sup>[4]</sup>
N-nitrosodi-N-propylamine	µg/L	5	<0.53	0.38 <sup>[13]</sup>	0	3
N-nitrosodiphenylamine	µg/L	5	<0.5	2.5 <sup>[13]</sup>	0	3
PAHs <sup>[18]</sup>	µg/L	5	<0.02	0.0088 <sup>[13]</sup>	0	3
PCBs <sup>[19]</sup>	µg/L	5	<0.69	0.000019 <sup>[13]</sup>	0	3
TCDD equivalents <sup>[20]</sup>	µg/L	5	<0.952	0.0000000039 <sup>[13]</sup>	0	3
1,1,2,2-tetrachloroethane	µg/L	NR	NR	2.3 <sup>[13]</sup>	0	3
Tetrachloroethylene	µg/L	5	<0.099	2.0 <sup>[13]</sup>	0	3
Toxaphene	µg/L	5	<0.18	0.00021 <sup>[13]</sup>	0	3
Trichloroethylene	µg/L	5	<0.11	27 <sup>[13]</sup>	0	3
1,1,2-trichloroethane	µg/L	5	<0.035	9.4 <sup>[13]</sup>	0	3
2,4,6-trichlorophenol	µg/L	5	<0.47	0.29 <sup>[13]</sup>	0	3
Vinyl chloride	µg/L	5	<0.15	36 <sup>[13]</sup>	0	3

NR = Data was unavailable for use in the RPA.

<sup>[1]</sup> Number of data points available for the RPA.

<sup>[2]</sup> If there is a detected value, the highest reported value is summarized in the table. If there are no detected values, the lowest MDL is summarized in the table.

<sup>[3]</sup> Note that the reported MEC does not account for dilution. The RPA does account for dilution; therefore it is possible for a parameter with an MEC in exceedance of the most stringent criteria not to present a RP (i.e., Endpoint 1).

<sup>[4]</sup> Endpoint 1 – RP determined, limit required, monitoring required.

Endpoint 2 – Discharger determined not to have RP, monitoring may be established.

Endpoint 3 – RPA was inconclusive, carry over previous limits if applicable, establish monitoring.

<sup>[5]</sup> Based on the 6-Month Median in Table 1 of the Ocean Plan.

<sup>[6]</sup> Background concentrations contained in Table 3 of the Ocean Plan.

<sup>[7]</sup> Based on the Daily Maximum in Table 1 of the Ocean Plan.

<sup>[8]</sup> Non-chlorinated phenolic compounds represent the sum of 2,4-dimethylphenol; 4,6-dinitro-2-methylphenol; 2,4,5-dinitrophenol; 2-methylphenol; 4-methylphenol; 2-nitrophenol; 4-nitrophenol; and phenol.

<sup>[9]</sup> Chlorinated phenolic compounds represent the sum of 4-chloro-3-methylphenol; 2-chlorophenol; pentachlorophenol; 2,4,5-trichlorophenol; and 2,4,6-trichlorophenol.

<sup>[10]</sup> Endosulfan represents the sum of alpha-endosulfan, beta-endosulfan, and endosulfan sulfate.

<sup>[11]</sup> HCH (hexachlorocyclohexane) represents the sum of the alpha, beta, gamma (Lindane), and delta isomers of hexachlorocyclohexane.

<sup>[12]</sup> Not to exceed limits specified in Title 17, Division 1, Chapter 5, Subchapter 4, Group 3, Article 3, Section 30253 of the California Code of Regulations.

<sup>[13]</sup> Based on 30-Day Average in Table 1 of the Ocean Plan.

<sup>[14]</sup> Dichlorobenzenes represent the sum of 1,2- and 1,3-dichlorobenzene.

<sup>[15]</sup> Chlordane represents the sum of chlordane-alpha, chlordane-gamma, chlordane-alpha, chlordane-gamma, nonachlor-alpha, nonachlor-gamma, and oxychlordane.

<sup>[16]</sup> DDT represents the sum of 4,4'-DDT; 2,4'-DDT; 4,4'-DDE; 2,4'-DDE; 4,4'-DDD; and 2,4'-DDD.

<sup>[17]</sup> Halomethanes represent the sum of bromoform, bromomethane (methyl bromide), and chloromethane (methyl chloride).

Parameter	Units	N <sup>[1]</sup>	MEC <sup>[2],[3]</sup>	Most Stringent Criteria	Background	RPA Endpoint <sup>[4]</sup>
-----------	-------	------------------	------------------------	-------------------------	------------	-----------------------------

- <sup>[18]</sup> PAHs (polynuclear aromatic hydrocarbons) represent the sum of acenaphthene; anthracene; 1,2-benzanthracene; 2,4-benzofluoranthene; benzo[k]fluoranthene; 1,12-benzoperylene; benzo[a]pyrene; chrysene; dibenzo[a,h]anthracene; fluorine; ideno[1,2,3-cd]pyrene; phenanthrene; and pyrene.
- <sup>[19]</sup> PCBs (polychlorinated biphenyls) represent the sum of chlorinated biphenyls whose analytical characteristics resemble those of Aroclor-1016, Aroclor-1221, Aroclor-1232, Aroclor-1242, Aroclor-1248, Aroclor-1254, and Aroclor-1260.
- <sup>[20]</sup> TCDD equivalents represent the sum of concentrations of chlorinated dibenzodioxins (2,3,7,8-CDDs) and chlorinated dibenzofurans (2,3,7,8-CDFs) multiplied by their respective toxicity factors, as shown by the table below. USEPA Method 8280 may be used to analyze TCDD equivalents.

Isomer Group	Toxicity Equivalence Factor
2,3,7,8 – tetra CDD	1.0
2,3,7,8 – penta CDD	0.5
2,3,7,8 – hexa CDD	0.1
2,3,7,8 – hepta CDD	0.01
octa CDD	0.001
2,3,7,8 – tetra CDF	0.1
1,2,3,7,8 – penta CDF	0.05
2,3,4,7,8 – penta CDF	0.5
2,3,7,8 – hexa CDFs	0.1
2,3,7,8 – hepta CDFs	0.01
octa CDF	0.001

#### 4. WQBEL Calculations

- a. From the Table 1 WQOs in the Ocean Plan, effluent limitations were calculated according to the following equation for all pollutants, except for acute toxicity and radioactivity:

$$C_e = C_o + D_m (C_o - C_s) \text{ where,}$$

$C_e$  = the effluent limitation ( $\mu\text{g/L}$ )

$C_o$  = the WQO to be met at the completion of initial dilution ( $\mu\text{g/L}$ )

$C_s$  = background seawater concentration

$D_m$  = minimum probable initial dilution expressed as parts seawater per part wastewater

- b. Initial dilution ( $D_m$ ) has been determined to be 122 to 1 by the Central Coast Water Board.
- c. Table 3 of the Ocean Plan establishes background concentrations for some pollutants to be used when determining reasonable potential (represented as “ $C_s$ ”). In accordance with Table 1 implementing procedures,  $C_s$  equals zero for all

pollutants not established in Table 3. The background concentrations provided in Table 3 are summarized below:

**Table F-10. Pollutants Having Background Concentrations**

<b>Pollutant</b>	<b>Background Seawater Concentration</b>
Arsenic	3 µg/L
Copper	2 µg/L
Mercury	0.0005 µg/L
Silver	0.16 µg/L
Zinc	8 µg/L

- d. Section III.C.4.J of the Ocean Plan requires effluent limitations to be expressed in terms of mass as well as concentration. However, this permit establishes a flow limitation of 7.64 MGD as well as concentration-based effluent limits. This effectively limits the mass and considers the intent of the Ocean Plan. Therefore this Order does not establish mass-based effluent limitations, which is consistent with the previous order.

**5. Whole Effluent Toxicity (WET)**

WET limitations protect receiving water from the aggregated toxic effect of a mixture of pollutants in effluent. WET tests measure the degree of response of exposed aquatic test organisms to an effluent. The WET approach allows for protection of the narrative “no toxics in toxic amounts” criterion while implementing numeric criteria for toxicity. There are two types of WET tests – acute and chronic. An acute test is conducted over a short time period and measures mortality. A chronic toxicity test is conducted over a longer period of time and may measure mortality, reproduction, and growth.

Order No. R3-2010-0012 established effluent limitations and quarterly monitoring for both acute and chronic toxicity. Based on the RPA, there is no reasonable potential determined to cause or contribute acute and chronic toxicity, therefore the limits were removed. Section III.C.4.c of the Ocean Plan requires a Discharger to conduct chronic toxicity testing for ocean waste discharges with minimum initial dilution ranging from 100:1 to 350:1. Therefore, quarterly monitoring for chronic toxicity has been carried over from the previous permit.

Although there is no effluent limitation established for chronic toxicity, the Discharger shall continue monitoring for any exceedances of a chronic toxicity trigger of 123 TUc, as established in this Order. The Discharger may be required to implement a Toxicity Reduction Evaluation (TRE) Workplan, as described in section VI.C.2.a of the Order. When monitoring measures WET in the effluent above the trigger established by the Order, the Discharger must resample, if the discharge is continuing, and retest. The Executive Officer will then determine whether to initiate enforcement action, whether to require the Discharger to implement a TRE, or to implement other measures.

**D. Final Effluent Limitation Considerations**

**1. Anti-Backsliding Requirements**

Sections 402(o) and 303(d)(4) of the CWA and federal regulations at 40 C.F.R. section 122.44(l) prohibit backsliding in NPDES permits. These anti-backsliding provisions

require effluent limitations in a reissued permit to be as stringent as those in the previous permit, with some exceptions where limitations may be relaxed. Where the RPA indicated that “reasonable potential” was inconclusive, limitations have been retained. For pollutants that resulted in Endpoint 2, concluding no “reasonable potential” exists, the limits were removed. Effluent limitations in this Order are consistent with antibacksliding requirements.

**2. Antidegradation Policies**

Provisions of this Order are consistent with applicable anti-degradation policy expressed by NPDES regulations at 40 CFR 131.12 and by State Water Board Resolution No. 68-16. The Order does not authorize increases in discharge rates or pollutant loadings, and its limitations and conditions otherwise ensure maintenance of the existing quality of receiving waters.

**3. Stringency of Requirements for Individual Pollutants**

This Order contains both technology-based and water quality-based effluent limitations for individual pollutants. The technology-based effluent limitations consist of restrictions on BOD, TSS, oil and grease, turbidity, pH, and settleable solids. Restrictions on these pollutants are discussed in the Fact Sheet, in section IV.B. This Order’s technology-based pollutant restrictions implement the minimum applicable federal technology-based requirements. In addition, this Order contains effluent limitations more stringent than the minimum federal technology-based requirements that are necessary to meet water quality standards. These limitations are not more stringent than required by the CWA.

**4. Summary of Final Effluent Limitations – Discharge Point No. 001**

**Table F-11. Final Effluent Limitations**

Parameter	Units	Effluent Limitations		
		Average Monthly	Average Weekly	Instantaneous Maximum
Biochemical Oxygen Demand 5-day @ 20°C (BOD <sub>5</sub> ) <sup>[1]</sup>	mg/L	30	45	---
	lbs/day <sup>[2]</sup>	1,912	2,867	---
Total Suspended Solids (TSS) <sup>[1]</sup>	mg/L	30	45	---
	lbs/day <sup>[2]</sup>	1,912	2,867	---
Oil and Grease	mg/L	25	40	75
	lbs/day <sup>[2]</sup>	1,590	2,549	4,779
Settleable Solids	ml/L/hr	1.0	1.5	3.0
Turbidity	NTU	75	100	225
Total Coliform Bacteria	<sup>[3]</sup>			
pH	standard units	6.0 – 9.0 at all times		

Parameter	Units	Effluent Limitations		
		Average Monthly	Average Weekly	Instantaneous Maximum

- <sup>[1]</sup> The average monthly percent removal for BOD and TSS shall not be less than 85 percent.
- <sup>[2]</sup> Mass based effluent limitations were calculated using the following formula:  
 lbs/day = pollutant concentration (mg/L) \* permitted flow (7.64 MGD) \* conversion factor (8.34)
- <sup>[3]</sup> 30-day Geometric Mean
  - Total coliform not to exceed 1,000 MPN/100 mL
  - Fecal coliform not to exceed 200 MPN/100 mL
  - Enterococcus not to exceed 35 MPN/100 mL
- Single Sample Maximum
  - Total coliform not to exceed 10,000 MPN/100 mL
  - Fecal coliform not to exceed 400 MPN/100 mL
  - Enterococcus not to exceed 104 MPN/100 mL
  - Total coliform not to exceed 1,000 MPN/100 mL when fecal coliform to total coliform ratio exceeds 0.1.

**Table F-12. Final Effluent Limitations, Protection of Marine Aquatic Life**

Parameter	Units	Effluent Limitation		
		6-Mo Median <sup>[1]</sup>	Maximum Daily <sup>[2]</sup>	Instantaneous Maximum <sup>[3]</sup>
Selenium	µg/L	1,845	7,348	18,450
Cyanide <sup>[4]</sup>	µg/L	123	492	1,230
Phenolic Compounds (non-chlorinated)	µg/L	3,690	14,760	36,900
Phenolic Compounds (chlorinated)	µg/L	123	492	1,230
Endosulfan	µg/L	1.107	2.214	3.321
Endrin	µg/L	0.246	0.492	0.738
HCH	µg/L	0.492	0.984	1.476
Radioactivity		<sup>[5]</sup>		

- <sup>1]</sup> The six-month median shall apply as a moving median of daily values for any 180-day period in which daily values represent flow weighted average concentrations within a 24-hour period. For intermittent discharges, the daily value shall be considered equal to zero for days on which no discharge occurred. The six-month median limit on daily mass emissions shall be determined using the six-month median effluent concentration  $C_e$  and the observed flow rate,  $Q$ , in million gallons per day (MGD).
- <sup>2]</sup> The daily maximum shall apply to flow weighted 24-hour composite samples. The daily maximum mass emission shall be determined using the daily maximum effluent concentration limit as  $C_e$  and the observed flow rate,  $Q$ , in MGD.
- <sup>3]</sup> The instantaneous maximum shall apply to grab sample determinations.
- <sup>4]</sup> If a Discharger can demonstrate to the satisfaction of the Central Coast Water Board (subject to USEPA approval) that an analytical method is available to reliably distinguish between strongly and weakly complexed cyanide, effluent limitations for cyanide may be met by the combined measurement of free cyanide, simple alkali metals cyanides, and weakly complexed organometallic cyanide complexes. In order for the analytical method to be acceptable, the recovery of free cyanide from metal complexes must be comparable to that achieved by the approved method in 40 CFR 136.
- <sup>5]</sup> Not to exceed limits specified in Title 17, Division 1, Chapter 5, Subchapter 4, Group 3, Article 3, Section 30253 of the California Code of Regulations

**Table F-13. Final Effluent Limitations – Protection of Human Health – Non-Carcinogens**

Parameter	Units	Effluent Limitation
		30-day Average
Acrolein	µg/L	27,060
Bis(2-chloroethoxy) methane	µg/L	541.2
Bis(2-chloroisopropyl) ether	µg/L	147,600
Chlorobenzene	µg/L	70,110
Di-n-butyl phthalate	µg/L	430,500
Dichlorobenzenes <sup>[1]</sup>	µg/L	627,300
Diethyl phthalate	µg/L	4.06E+06
Dimethyl phthalate	µg/L	1.01E+08
4,6-dinitro-2-methylphenol	µg/L	27,060
2,4-dinitrophenol	µg/L	492
Ethylbenzene	µg/L	504,300
Fluoranthene	µg/L	1,845
Hexachlorocyclopentadiene	µg/L	7,134
Nitrobenzene	µg/L	603
Thallium	µg/L	246
Toluene	µg/L	1.05E+07
Tributyltin	µg/L	0.172
1,1,1-trichloroethane	µg/L	6.64E+07

<sup>[1]</sup> Sum of 1,2- and 1,3-dichlorobenzene.

**Table F-14. Final Effluent Limitations – Protection of Human Health – Carcinogens**

Parameter	Units	Effluent Limitation
		30-day Average
Acrylonitrile	µg/L	12.3
Aldrin	µg/L	0.0027
Benzene	µg/L	725.7
Benzidine	µg/L	0.0085
Beryllium	µg/L	4.059
Bis(2-ethylhexyl) phthalate	µg/L	5.535
Carbon tetrachloride	µg/L	110.7
Chlorodibromomethane	µg/L	0.0028
Chloroform	µg/L	1,057
DDT <sup>[1]</sup>	µg/L	0.02091
1,4-dichlorobenzene	µg/L	2,214
3,3-dichlorobenzidine	µg/L	0.9963
1,2-dichloroethane	µg/L	3,444
1,1-dichloroethylene	µg/L	110.7
Dichlorobromomethane	µg/L	762.6
Dichloromethane	µg/L	55,350
1,3-dichloropropene	µg/L	1,094
Dieldrin	µg/L	0.00492
2,4-dinitrotoluene	µg/L	319.8



Parameter	Units	Effluent Limitation
		30-day Average
1,2-diphenylhydrazine	µg/L	19.68
Heptachlor	µg/L	0.00615
Heptachlor epoxide	µg/L	0.00246
Hexachlorobenzene	µg/L	0.02583
Hexachlorobutadiene	µg/L	1,722
Hexachloroethane	µg/L	307.5
Isophorone	µg/L	89,790
N-nitrosodimethylamine	µg/L	897.9
N-nitrosodi-n-propylamine	µg/L	46.74
N-nitrosodiphenylamine	µg/L	307.5
PAHs <sup>[2]</sup>	µg/L	1.0824
PCBs <sup>[3]</sup>	µg/L	0.0023
TCDD equivalents <sup>[4]</sup>	µg/L	0.48
1,1,2,2-tetrachloroethane	µg/L	282.9
Tetrachloroethylene	µg/L	246
Toxaphene	µg/L	0.026
Trichloroethylene	µg/L	3,321
1,1,2-trichloroethane	µg/L	1,156
2,4,6-trichlorophenol	µg/L	36.67
Vinyl chloride	µg/L	4,428

[1] Sum of 4,4'-DDT, 2,4'-DDT, 4,4'-DDE, 2,4'-DDE, 4,4'-DDD, and 2,4'-DDD.

[2] Sum of acenaphthylene, anthracene, 1,2-benzanthracene, 3,4-benzofluoranthene, benzo[k]fluoranthene, 1,1,2-benzoperylene, benzo[a]pyrene, chrysene, dibenzo[a,h]anthracene, fluorine, ideno[1,2,3-cd]pyrene, phenanthrene, and pyrene.

[3] Sum of chlorinated biphenyls whose analytical characteristics resemble those of Aroclor-1016, Aroclor-1221, Aroclor-1232, Aroclor-1242, Aroclor-1248, Aroclor-1254, and Aroclor-1260.

[4] TCDD equivalents shall mean the sum of the concentrations of chlorinated dibenzodioxins (2,3,7,8-CDDs) and chlorinated dibenzofurans (2,3,7,8-CDFs) multiplied by their respective toxicity factors, as shown below:

Isomer Group	Toxicity Equivalent Factor	Isomer Group	Toxicity Equivalent Factor
2,3,7,8-tetra CDD	1.0	1,2,3,7,8-penta CDF	0.05
2,3,7,8-penta CDD	0.5	2,3,4,7,8-penta CDF	0.5
2,3,7,8-hexa CDDs	0.1	2,3,7,8-hexa CDFs	0.1
2,3,7,8-hepta CDD	0.01	2,3,7,8-hepta CDFs	0.01
octa CDD	0.001	octa CDF	0.001
2,3,7,8-tetra CDF	0.1	--	--

**a. Percent Removal**

The average monthly percent removal of BOD<sub>5</sub> and TSS shall not be less than 85 percent.

**b. Bacteria**

The following bacterial objectives shall be maintained throughout the water column:

- i. 30-day Geometric Mean
  - (a) Total coliform not to exceed 1,000 MPN/100 mL
  - (b) Fecal coliform not to exceed 200 MPN/100 mL
  - (c) Enterococcus not to exceed 35 MPN/100 mL
- ii. Single Sample Maximum
  - (a) Total coliform not to exceed 10,000 MPN/100 mL
  - (b) Fecal coliform not to exceed 400 MPN/100 mL
  - (c) Enterococcus not to exceed 104 MPN/100 mL
  - (d) Total coliform not to exceed 1,000 MPN/100 mL when fecal coliform to total coliform ratio exceeds 0.1.

**E. Interim Effluent Limitations – Not Applicable**

**F. Land Discharge Specifications – Not Applicable**

**G. Recycling Specifications**

On September 13, 1991, the Central Coast Water Board adopted Waste Discharge Requirements Order No. 91-03 allowing the Discharger to produce reclaimed water. Since then, the Discharger has distributed most of the reclaimed water it produces to the Goleta Water District.

7. Reclamation use of tertiary treated wastewater shall comply with applicable state and local requirements regarding the production and use of reclaimed wastewater, including requirements of California Water Code (CWC) sections 13500-13577 (Water Reclamation) and Division of Drinking Water (DDW) regulations at Title 22, sections 60301-60355 of the California Code of Regulations (Water Recycling Criteria).
8. Recycled water production shall comply with a title 22 engineering report approved by the Division of Drinking Water that demonstrates or defines compliance with the Uniform Statewide Recycling Criteria (and amendments).
9. Recycled water shall be disinfected tertiary recycled water, as defined by Title 22, section 60301.230.
10. Recycled water shall be adequately oxidized, filtered, and disinfected, as defined in Title 22.
11. The Discharger shall comply with the following specifications at Discharge Point No. 002 for reclamation of tertiary treated secondary wastewater as described in the attached MRP (Attachment E).

12. The Discharger shall comply with the following specifications at Discharge Point No. 002 for reclamation of tertiary treated secondary wastewater, with compliance measured at Monitoring Location EFF-002, as described in the attached MRP.

Parameter	Units	Effluent Limitations	
		Average Monthly	Maximum Daily
BOD <sub>5</sub>	mg/L	10	25
TSS	mg/L	10	25

2. Recycled water shall not exceed any of the following turbidity limits:
  - a. An average of 2 NTU within a 24-hour period,
  - b. 5 NTU more than 5 percent of the time within a 24-hour period, and
3. The median concentration of total coliform bacteria measured in the disinfected recycled water shall not exceed the following limits:
  - a. An MPN of 2.2 per 100 mL utilizing the bacteriological results of the last seven days for which analyses have been completed,
  - b. An MPN of 23 per 100 mL in more than one sample in any 30 day period, and
  - c. No sample shall exceed an MPN of 240 total coliform bacteria per 100 mL.
4. Recycled water disinfected with chlorine shall have a CT value (chlorine concentration time modal contact time) of not less than 40 mg-min/L at all times with a modal contact time of at least 90 minutes based on a flow of 3.3 MGD.
5. No irrigation use with treated effluent shall take place within 50 feet of any domestic water supply well.
6. No impoundment of treated effluent shall occur within 100 feet of any domestic water supply well.
7. Reclaimed water shall be confined to areas of authorized use without discharge to surface waters or drainage ways.
8. Personnel involved in producing, transporting, or using reclaimed water shall be informed of possible health hazards that may result from contact and use of reclaimed water.
9. Spray irrigation of reclaimed water shall be accomplished at a time and in a manner to minimize ponding and contact with the public.
10. Delivery of reclaimed water shall be discontinued when these Reclamation Specifications cannot be met.
11. All reclamation reservoirs and other areas with public access shall be posted, in English and Spanish, to warn the public that reclaimed wastewater is being stored or used.
12. Reclaimed water systems shall be properly labeled and regularly inspected to ensure proper operation, absence of leaks, and absence of illegal connections.

**V. RATIONALE FOR RECEIVING WATER LIMITATIONS**

**A. Surface Water**

Receiving water quality is a result of many factors, some unrelated to the discharge. This Order considers these factors and is designed to minimize the influence of the discharge on the receiving water. Receiving water limitations for Discharge Point No. 001 to the Pacific Ocean are consistent with the water quality objectives contained in the Ocean Plan and Basin Plan.

**B. Groundwater → Not Applicable**

**VI. RATIONALE FOR MONITORING AND REPORTING REQUIREMENTS**

40 CFR Section 122.48 requires that all NPDES permits specify requirements for recording and reporting monitoring results. Water Code sections 13267 and 13383 authorize the Central Coast Water Board to require technical and monitoring reports. The Monitoring and Reporting Program (MRP), Attachment E, establishes monitoring and reporting requirements that implement federal and state requirements. The following provides the rationale for the monitoring and reporting requirements contained in the MRP for this facility.

**A. Influent Monitoring**

In addition to influent flow monitoring, monitoring for BOD<sub>5</sub> and TSS is required to determine compliance with the Order's percent removal requirement for these pollutants. Influent monitoring requirements have been retained from the previous Order.

**B. Effluent Monitoring**

Effluent monitoring is necessary to determine compliance with effluent limitations and evaluate compliance with applicable water quality objectives and criteria. Monitoring for ammonia, arsenic, cadmium, chromium VI, copper, lead, mercury nickel, silver, zinc, selenium, and cyanide have been reduced from monthly to annually because these parameters did not exhibit any reasonable potential. Acute toxicity monitoring has been removed because there was no reasonable potential for acute toxicity in the previous permit term. All other effluent monitoring requirements from the previous Order (R3-2010-0012) for Discharge Point No. 001 are retained in this Order.

**C. Whole Effluent Toxicity Testing Requirements**

Whole effluent toxicity (WET) limitations protect receiving water quality from the aggregate toxic effect of a mixture of pollutants in the effluent. Acute toxicity testing measures mortality in 100 percent effluent over a short test period and chronic toxicity testing is conducted over a longer period of time and may measure mortality, reproduction, and/or growth. This Order retains monitoring requirements for chronic toxicity for Discharge Point No. 001, but has removed limitations based on a conclusion that no reasonable potential for toxicity exists. A chronic toxicity trigger of 123 TUc, which has been calculated consisted with the prescribed method in the 2012 Ocean Plan, has been established for this Order to determine if a TRE is required. Because there is no reasonable potential for acute toxicity and the 2012 Ocean Plan does not state any required monitoring, acute toxicity monitoring has been removed.

**D. Land Discharge Monitoring Requirements → Not Applicable**

**E. Reclaimed Water Specifications**

Influent and effluent monitoring is necessary to ensure that the Discharger produces reclaimed water that meets Title 22 Water Recycling Criteria. Reclaimed water monitoring and reporting have been carried over from Waste Discharge Requirements Order No. 91-03.

**F. Receiving Water Monitoring**

**1. Surface Water**

With the upgrade to full secondary treatment, surface water receiving water monitoring requirements are retained from the previous Order, as necessary, and in order to be consistent with similar NPDES dischargers. The monitoring is consistent with the 2015 Ocean Plan, to determine compliance with surface water limitations and for the protection of public health.

**2. Groundwater – Not Applicable**

**G. Other Monitoring Requirements**

**1. Biosolids/Sludge Monitoring**

Biosolids monitoring requirements have been carried over from the previous permit.

**2. Pretreatment Monitoring**

Pretreatment monitoring requirements have been carried over from the previous order. These requirements are authorized under 40 CFR Part 403.8.

**3. Outfall Inspection**

The Order retains the requirement of the previous permit to conduct annual visual inspections of the outfall and diffuser system and provide a report of this inspection to the Regional Water Board regarding the system's physical integrity.

**VII. RATIONALE FOR PROVISIONS**

**A. Standard Provisions**

Standard Provisions, which apply to all NPDES permits in accordance with 40 C.F.R. section 122.41, and additional conditions applicable to specified categories of permits in accordance with 40 C.F.R. section 122.42, are provided in Attachment D to the order.

Sections 122.41(a)(1) and (b) through (n) of 40 C.F.R. establish conditions that apply to all State-issued NPDES permits. These conditions must be incorporated into the permits either expressly or by reference. If incorporated by reference, a specific citation to the regulations must be included in the Order. Section 123.25(a)(12) allows the State to omit or modify conditions to impose more stringent requirements. In accordance with 40 C.F.R. section 123.25, this Order omits federal conditions that address enforcement authority specified in 40 C.F.R. sections 122.41(j)(5) and (k)(2) because the enforcement authority under the Water Code is more stringent. In lieu of these conditions, this Order incorporates by reference Water Code section 13387(e).

**B. Special Provisions**

**1. Reopener Provisions**

The Order may be modified in accordance with the requirements set forth at 40 CFR 122 and 124, to include appropriate conditions or limits based on newly available information,

or to implement any new State water quality objectives that are approved by the USEPA. As effluent is further characterized through additional monitoring, and if a need for additional effluent limitations becomes apparent after additional effluent characterization, the Order will be reopened to incorporate such limitations.

## **2. Special Studies and Additional Monitoring Requirements**

### **a. Toxicity Reduction Requirements**

The requirement to maintain a Toxicity Reduction Work Plan is retained from Order No. R3-2010-0012. When toxicity monitoring measures chronic toxicity in the effluent above the trigger of 123 TUC established by the Order, the Discharger is required to resample and retest, if the discharge is continuing. When all monitoring results are available, the Executive Officer can determine whether to initiate enforcement action, whether to require the Discharger to implement toxicity reduction evaluation (TRE) requirements, or whether other measures are warranted.

## **3. Best Management Practices and Pollution Prevention**

### **a. Pollutant Minimization Program**

The 2012 Ocean Plan establishes guidelines for the Pollutant Minimization Program (PMP). The 2012 Ocean Plan PMP language is included in this Order to provide guidance in the event that a PMP must be developed and implemented by the Discharger. The discharger is required to develop a PMP only if required to do so in writing by the Executive Officer.

## **4. Construction, Operation, and Maintenance Specifications – Not Applicable**

## **5. Special Provisions for Municipal Facilities (POTWs Only)**

### **a. Biosolids Management**

The use and disposal of biosolids is regulated under federal and State laws and regulations, including permitting requirements and technical standards included in 40 C.F.R. 503, and as such the Discharger is required to comply with the standards and time schedules within 40 C.F.R. 503.

Title 27, CCR, Division 2, Subdivision 1, Section 20005 establishes approved methods for the disposal of collected screenings, residual sludge, biosolids, and other solids removed from liquid wastes. Requirements to ensure the Discharger disposes of solids in compliance with State and federal regulations have been included in this Order. These requirements have been retained from the previous Order.

### **b. Pretreatment**

Pretreatment requirements for POTWs are contained within 40 CFR Part 403. Per 40 CFR Part 403.8, any POTW (or combination of POTWs operated by the same authority) with a total design flow greater than 5 million gallons per day (MGD) and receiving from industrial users pollutants which pass through or interfere with the operation of the POTW or are otherwise subject to pretreatment standards will be required to establish a POTW pretreatment program unless the NPDES State exercises its option to assume local responsibilities as provided for in §403.10(e). The Executive Officer may require that a POTW with a design flow of 5 MDG or less develop a POTW pretreatment program if he or she finds that the nature or volume

of the industrial influent, treatment process upsets, violations of POTW effluent limitations, contamination of municipal sludge, or other circumstances warrant in order to prevent interference with the POTW or pass through as defined in 40 CFR Part 403.3.

The Order/Permit retains pretreatment requirements as the Facility has total effluent flows in excess of 5 MGD and a number of significant industrial users.

## 6. Other Special Provisions

### a. Discharges of Storm Water.

For the control of storm water discharged from the site of the wastewater treatment plant and disposal facilities, if applicable, the Discharger shall seek authorization to discharge under and meet the requirements of the State Water Resources Control Board's Water Quality Order 2014-0057-DWQ, NPDES General Permit No. CAS000001, *Waste Discharge Requirements for Discharges of Storm Water Associated with Industrial Activities Excluding Construction Activities*.

### b. Statewide General Waste Discharge Requirements for Sanitary Sewer Systems (State Water Board Order No. 2006-003-DWQ).

The Order requires coverage by and compliance with applicable provisions of General Waste Discharge Requirements for Sanitary Sewer Systems (State Water Board Order No. 2006-003-DWQ). This General Permit, adopted on May 2, 2006, is applicable to all "federal and state agencies, municipalities, counties, districts, and other public entities that own or operate sanitary sewer systems greater than one mile in length that collect and/or convey untreated or partially treated wastewater to a publicly owned treatment facility in the State of California." The purpose of the General Permit is to promote the proper and efficient management, operation, and maintenance of sanitary sewer systems and to minimize the occurrences and impacts of sanitary sewer overflows.

## 7. Compliance Schedules – Not Applicable

## VIII. PUBLIC PARTICIPATION

The California Regional Water Quality Control Board, Central Coast Region (Central Coast Water Board) considered the issuance of waste discharge requirements (WDRs) that serve as a National Pollutant Discharge Elimination System (NPDES) permit for Goleta Sanitary District Water Resource Recovery Facility. As a step in the WDR adoption process, the Central Coast Water Board staff developed tentative WDRs and the Central Coast Water Board encouraged public participation in the WDR adoption process.

### A. Notification of Interested Parties

The Central Coast Water Board notified the Discharger and interested agencies and persons of its intent to prescribe WDRs for the discharge and provided an opportunity to submit written comments and recommendations. Notification was provided through publication in the Santa Barbara News Press on June 15, 2017 and posting at the facility.

The Central Coast Water Board's web address is <http://www.waterboards.ca.gov/centralcoast/> where the public was provided access to the agenda including any changes in dates and locations.

**B. Written Comments**

Interested persons were invited to submit written comments concerning tentative WDRs as provided through the notification process. Comments were due either in person, via electronic mail (centralcoast@waterboards.ca.gov) or by mail to the Executive Office at the Central Coast Water Board at:

Central Coast Regional Water Quality Control Board  
895 Aerovista Place, Suite 101  
San Luis Obispo, CA 93401-7906

To be fully responded to by staff and considered by the Central Coast Water Board, the written comments were due at the Central Coast Water Board office by 5:00 p.m. on July 21, 2017. No public comments were received during the public comment period.

**C. Public Hearing**

The Central Coast Water Board held a public hearing on the tentative WDRs during its regular Board meeting on the following date and time and at the following location:

Date: September 21, 2017  
Time: 9:00 a.m.  
Location: Santa Barbara County Offices  
Planning & Development Hearing Room, 1<sup>st</sup> Floor Room  
105 East Anapamu Street  
Santa Barbara, CA 93101

Interested persons were invited to attend the public hearing and provide testimony to the Central Coast Water Board pertinent to the discharge, WDR's, and permit. For accuracy of the record, important testimony was requested in writing. No public provided comments during the meeting and the WDRs were approved on the consent calendar.

**D. Reconsideration of Waste Discharge Requirements**

Any aggrieved person may petition the State Water Board to review the decision of the Regional Water Board regarding the final WDRs. The petition must be received by the State Water Board at the following address within 30 calendar days of the Regional Water Board's action.

State Water Resources Control Board  
Office of Chief Counsel  
P.O. Box 100, 1001 I Street  
Sacramento, CA 95812-0100

For instructions on how to file a petition for review, see:  
[http://www.waterboards.ca.gov/public\\_notices/petitions/water\\_quality/wqpetition\\_instr.shtml](http://www.waterboards.ca.gov/public_notices/petitions/water_quality/wqpetition_instr.shtml)

**E. Information and Copying**

The Report of Waste Discharge, other supporting documents, and comments received are on file and may be inspected at the address above at any time between 8:00 a.m. and 5:00 p.m., Monday through Friday. Copying of documents may be arranged through the Central Coast Water Board by calling (805) 549-3147.



**F. Register of Interested Persons**

Any person interested in being placed on the mailing list for information regarding the WDRs and NPDES permit should contact the Central Coast Water Board, reference this Facility, and provide a name, address, and phone number.

**G. Additional Information**

Requests for additional information or questions regarding this order should be directed to Peter von Langen at (805) 549-3688 or [Peter.vonLangen@waterboards.ca.gov](mailto:Peter.vonLangen@waterboards.ca.gov) or Sheila Soderberg at (805) 549-3592 or [Sheila.Soderberg@waterboards.ca.gov](mailto:Sheila.Soderberg@waterboards.ca.gov).